

A guide to **recirculation aquaculture**

An introduction to the new environmentally friendly and highly productive closed fish farming systems

Jacob Bregnballe

2022 edition



Food and Agriculture
Organization of the
United Nations



A guide to recirculation aquaculture

An introduction to the new environmentally friendly and highly productive closed fish farming systems

Jacob Bregnballe

Published by the
Food and Agriculture Organization of the United Nations (FAO)
and
Eurofish International Organisation

Required citation:

Bregnballe, J. 2022. *A guide to recirculation aquaculture – An introduction to the new environmentally friendly and highly productive closed fish farming systems*. Rome. FAO and Eurofish International Organisation. <https://doi.org/10.4060/cc2390en>

The designations employed and the presentation of material in this information product do not imply the expression of any opinion whatsoever on the part of the Food and Agriculture Organization of the United Nations (FAO) or Eurofish International Organisation concerning the legal or development status of any country, territory, city or area or of its authorities, or concerning the delimitation of its frontiers or boundaries. The mention of specific companies or products of manufacturers, whether or not these have been patented, does not imply that these have been endorsed or recommended by FAO or Eurofish International Organisation in preference to others of a similar nature that are not mentioned. For images where no references are mentioned, AKVA group is the source.

The views expressed in this information product are those of the author(s) and do not necessarily reflect the views or policies of FAO or Eurofish International Organisation.

ISBN 978-92-5-136981-4 [FAO]

© FAO and Eurofish International Organisation, 2022 (3rd edition)



Some rights reserved. This work is made available under the Creative Commons Attribution-NonCommercial-ShareAlike 3.0 IGO licence (CC BY-NC-SA 3.0 IGO; <https://creativecommons.org/licenses/by-nc-sa/3.0/igo/legalcode>).

Under the terms of this licence, this work may be copied, redistributed and adapted for non-commercial purposes, provided that the work is appropriately cited. In any use of this work, there should be no suggestion that FAO or Eurofish endorses any specific organization, products or services. The use of the FAO and Eurofish logo is not permitted. If the work is adapted, then it must be licensed under the same or equivalent Creative Commons license. If a translation of this work is created, it must include the following disclaimer along with the required citation: "This translation was not created by the Food and Agriculture Organization of the United Nations (FAO) or Eurofish. FAO or Eurofish are not responsible for the content or accuracy of this translation. The original [Language] edition shall be the authoritative edition."

Disputes arising under the licence that cannot be settled amicably will be resolved by mediation and arbitration as described in Article 8 of the licence except as otherwise provided herein. The applicable mediation rules will be the mediation rules of the World Intellectual Property Organization <http://www.wipo.int/amc/en/mediation/rules> and any arbitration will be in accordance with the Arbitration Rules of the United Nations Commission on International Trade Law (UNCITRAL)

Third-party materials. Users wishing to reuse material from this work that is attributed to a third party, such as tables, figures or images, are responsible for determining whether permission is needed for that reuse and for obtaining permission from the copyright holder. The risk of claims resulting from infringement of any third-party-owned component in the work rests solely with the user.

Sales, rights and licensing. This product is available on the FAO website (www.fao.org/publications) and the Eurofish website (www.eurofish.dk/activities/publications/) and can be purchased through publications-sales@fao.org or info@eurofish.dk. Requests for commercial use should be submitted via: www.fao.org/contact-us/licence-request. Queries regarding rights and licensing should be submitted to: copyright@fao.org or info@eurofish.dk

Contents

Foreword.....	v
Chapter 1: Introduction to recirculation aquaculture.....	1
Chapter 2: The recirculation system step by step.....	7
Chapter 3: Fish species in recirculation.....	35
Chapter 4: Project planning and implementation.....	45
Chapter 5: Running a recirculation system.....	55
Chapter 6: Waste water treatment.....	75
Chapter 7: Disease.....	85
Chapter 8: Case stories.....	93
References.....	103
Appendix – Checklist when implementing a recirculation system.....	105

Foreword

Stringent environmental restrictions to minimise pollution from hatcheries and land-based aquaculture facilities in northern European countries have sparked the rapid technological development, investment and innovation in recirculation systems in many parts of the world. Recirculation also secures a higher and more stable aquaculture production with fewer diseases and better ways to control the hatchery parameters that influence fish growth in aquaculture production systems. This development is welcome and fully in line with the FAO Code of Conduct for Responsible Fisheries. The present guideline on recirculation aquaculture supplements the environmentally sustainable aquaculture work of the FAO Regional Office for Europe and Central Asia. The water recirculation technique also implies that hatcheries no longer necessarily need to be placed in pristine areas near rivers. Now they can be built almost anywhere with a much smaller source of clean germ-free water. It has therefore been a pleasure for FAO to support the production of this guide which we hope can inspire and help fish farmers to increasingly adopt recirculation systems in the future.



Haydar Fersoy
Senior Fisheries and Aquaculture Officer
FAO Regional Office for Europe and Central Asia

Already one of the world's fastest growing agrifood sectors, aquaculture has the potential for further growth in providing the world's population with high quality and healthy fish and seafood products. While global capture production has been fairly stable over the last decade reaching 92 million tonnes in 2019, aquaculture production was 85 million tonnes, a 48 percent increase since 2010.

Increased focus on sustainability, consumer demands, food safety and cost effectiveness in aquaculture production calls for the continuous development of new production technologies. In general, aquaculture production affects the environment, but state-of-the-art recirculation methods reduce this effect considerably compared to traditional ways of farming fish. Recirculation systems thereby offer two immediate advantages: cost effectiveness and reduced environmental impact. This guide focuses on the techniques for the conversion from traditional farming methods to recirculated aquaculture and advises the farmer on the pitfalls to be avoided along the way.

The guide is based on the experience of one of the foremost experts in this area, Jacob Bregnballe from the AKVA group. It is hoped that the guide will be a useful tool for fish farmers who are considering converting to recirculation systems.



Marco Frederiksen
Director
Eurofish International Organisation

Introduction to the author Jacob Bregnballe and the AKVA group

Jacob Bregnballe from AKVA group has been working with recirculation aquaculture for more than 40 years. He has been running his own fish farm in Denmark for 25 years and has been involved in many technological innovations for improving recirculation systems for a wide range of different aquaculture species. He has also worked as an international aquaculture consultant and holds a master's degree from Copenhagen University. Today he is the Sales Director of the Land Based division in AKVA group, one of the largest aquaculture technology companies in the world covering all aspects of aquaculture production both on shore and at sea. The company has more than 40 years of experience in the design and manufacture of sea based net pens, feed barges, feeding systems, environmental sensors, and fish farming software. In the Land Based division, the company provides turn-key solutions for recirculation aquaculture projects.



Jacob Bregnballe
AKVA group Land Based A/S
Venusvej 24, 7000 Fredericia
Denmark

Mob.: (+45) 2068 0994
jbregnballe@akvagroup.com
www.akvagroup.com

Chapter 1: Introduction to recirculation aquaculture

Recirculation aquaculture is essentially a technology for farming fish or other aquatic organisms by reusing the water in the production. The technology is based on the use of mechanical and biological filters, and the method can in principle be used for any species grown in aquaculture such as fish, shrimps, clams, etc. Recirculation technology is however primarily used in fish farming, and this guide is aimed at people working in this field of aquaculture.

The use of recirculation aquaculture systems (RAS) is growing rapidly in many areas of the fish farming sector, and systems are deployed in production units that vary from huge plants generating many tonnes of fish per year for consumption to small sophisticated systems used for restocking or to save endangered species.

Recirculation can be carried out at different intensities depending on how much water is recirculated or re-used. Many RAS today are intensive farming systems installed inside a closed insulated building using as little as 300 L of new water per kilogram of fish produced. The consumption of water can be reduced even further to only 30–40 L per kg fish produced if denitrification and phosphorus removal is installed in connection to the RAS circuit. Other systems are traditional outdoor farms that have often been rebuilt into a recirculation system using around 3 m³ new water per kilogram of fish produced. A traditional flow-through system for trout where the water is just passes through the farm once before it

Figure 1.1 An indoor recirculation system



is discharged will typically use around 30 m³ per kg of fish produced, which is around 100 times more water than a typical RAS will use.

Another way of expressing the degree of recirculation is by using the formula:

$$(Internal\ recirculation\ flow / [internal\ recirculation\ flow + new\ water\ intake]) \times 100$$

The formula has been used in Figure 1.2 for calculating the degree of recirculation at different system intensities, compared also to other ways of measuring the rate of recirculation.

Table 1.1 Comparison of degree of recirculation at different intensities compared to other ways of expressing the rate of recirculation

Type of system	Consumption of new water per kg fish produced	Consumption of new water per hour	Consumption of new water/day of system volume	Degree of recirculation using formula
Flow-through	30 m ³	1 712 m ³ /h	1 028 %	0 %
RAS low level	3 m ³	171 m ³ /h	103 %	95.9 %
RAS intensive	0.3 m ³	17 m ³ /h	10 %	99.6 %
RAS with N and P removal	0.03 m ³	1.7 m ³ /h	1 %	99.96 %

The calculations are based on a theoretical example of a 500 tonnes/year system recycling the water once per hour at feed conversion rate 1.0 with a total water volume of 4 000 m³ of which 3 000 m³ is the fish tank volume.

Seen from an environmental point of view, the limited amount of water used in recirculation is of course beneficial as water has become a limited resource in many regions. Also, the limited use of water makes it easier and cheaper to remove the nutrients excreted from the fish as the volume of discharged water is much lower than that discharged from a traditional fish farm. Recirculation aquaculture can therefore be considered a most environmentally friendly way of producing fish at a commercially viable level. The nutrients from the farmed fish can be used as fertilizer on farmland or for biogas production.

Figure 1.2 An outdoor recirculation farm



The term “zero water usage” or “zero-discharge” is sometimes used in connection to fish farming, and although it is possible to avoid all discharge from the farm of sludge and water, the waste water treatment to remove the very last residues is usually a costly affair. It is therefore advised to apply for a discharge permit that allows for discharging nutrients at a level that makes the project financially viable and at the same time minimises the impact on the environment.

Most interesting though, is the fact that the limited use of water gives a huge benefit to the production inside the fish farm. Traditional fish farming is totally dependent on external conditions such as the water temperature of the river, cleanliness of the water, oxygen levels, or weed and leaves drifting downstream and blocking the inlet screens, etc. In a recirculated system these external factors are eliminated either completely or partly, depending on the degree of recirculation and the construction of the plant.

Recirculation enables the fish farmer to completely control all the parameters in the production, and the skills of the farmer to operate the recirculation system itself becomes just as important as his ability to take care of the fish.

Controlling parameters such as water temperature, oxygen levels, or daylight for that matter, gives stable and optimal conditions for the fish, which again gives less stress and better growth. These stable conditions result in a steady and foreseeable growth pattern that enables the farmer to precisely predict when the

Figure 1.3 Some of the parameters affecting the growth and well-being of a farmed fish

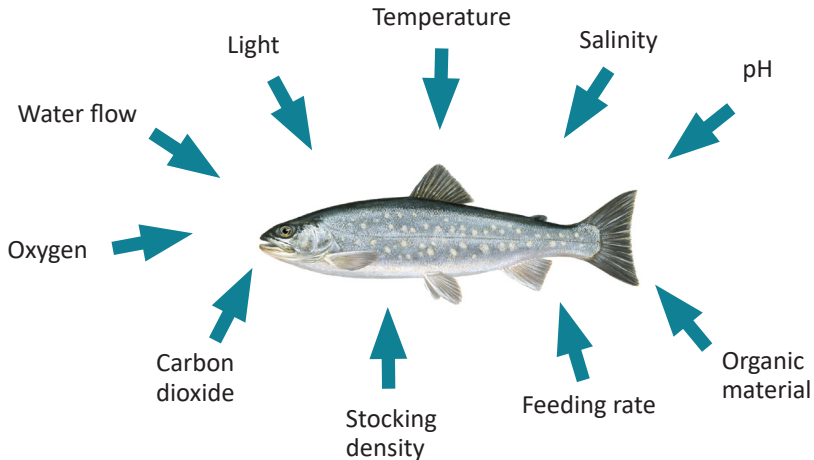

fish will have reached a certain stage or size. The major advantage of this feature is that a precise production plan can be drawn up and that the exact time the fish will be ready for sale can be predicted. This favours the overall management of the farm and strengthens the ability to market the fish in a competitive way.

There are many more advantages of using recirculation technology in fish farming, and this guide will deal with these aspects in the following chapters. However, one major aspect to be mentioned right away is that of diseases. The impact of pathogens is lowered considerably in a recirculation system as invasive diseases from the outside environment are minimised by the limited use of water. Water for traditional fish farming is taken from a river, a lake or the sea, which naturally increases the risk of dragging in diseases. Due to the limited use of water in recirculation the water is often taken from a borehole, drainage system or spring where the risk of diseases is minimal. Moreover, many RAS treat the intake water with ultraviolet light or ozone to kill off any unwanted organisms. In fact, many recirculation systems do not have any problems with diseases whatsoever, and the use of medicine is therefore reduced significantly for the benefit of the production and the environment. To reach this level of farming practice it is of course extremely important that the fish farmer is very careful about the eggs or fry entering the farm. Many diseases can be carried into systems by taking in infested eggs or fish for stocking. The best way to avoid diseases entering this way, is not to bring in fish from outside, but only bring in eggs as these can be disinfected completely against most diseases.

The design of a complete RAS farm should consider that fish have different requirements according to their living stage and size. It is important that the farm is designed with independent modules operating as isolated units that match the specific needs at the different growth stages. Separating the farm into different modules secures the right size of fish with the right size of tanks, the right feeding capacity available, the right light regime etc. Having different modules not only responds to the biological needs of the fish and improves the efficiency of farm management, but also increases biosecurity at the farm during production and prevents diseases from spreading.

Aquaculture requires knowledge, good husbandry, persistence and sometimes nerves of steel. Shifting from traditional fish farming into recirculation does make many things easier, however at the same time it requires new skills. To be a successful operator of these highly advanced aquaculture systems calls for training and education for which purpose this guide has been written.

Figure 1.4 A modern RAS split into different modules to make the system design match the specific needs of fish at different growth stages

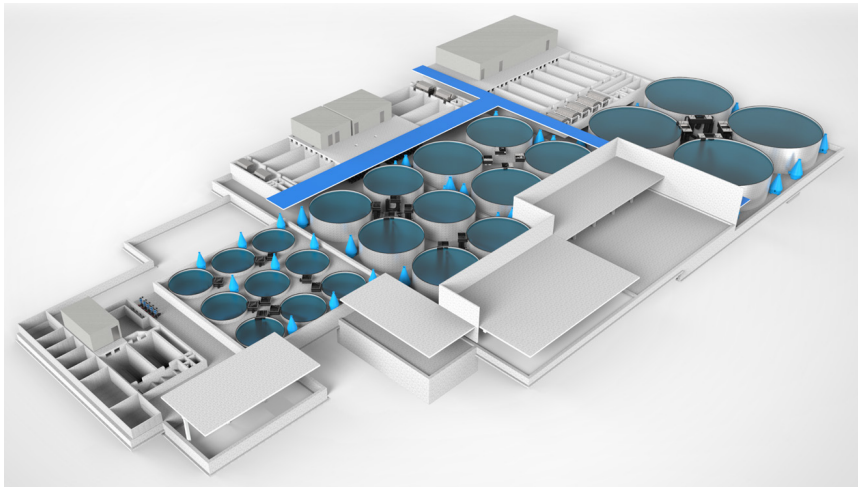

Chapter 2: The recirculation system, step by step

In a recirculation system it is necessary to treat the water continuously to remove the waste products excreted by the fish, and to add oxygen to keep the fish alive and well. A recirculation system is in fact quite simple: From the outlet of the fish tanks the water flows to a mechanical filter and further on to a biological filter, hereafter the water is degassed and stripped of carbon dioxide and then returned to the fish tanks. This is the basic principle of recirculation.

Several other facilities can be added, such as oxygenation with pure oxygen, ultraviolet light (UV) or ozone treatment, automatic pH regulation, heat exchanging, denitrification, etc. depending on the exact requirements.

Figure 2.1 Principle drawing of a recirculation system

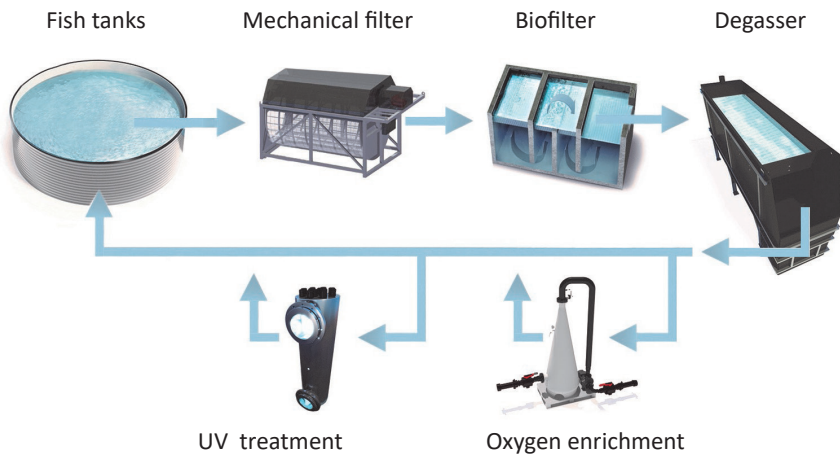

The basic water treatment system consists of mechanical filtration, biological treatment and degassing. Further installations, such as oxygen enrichment or UV treatment, can be added depending on the requirements.

Fish in a fish farm require feeding several times a day. The feed is eaten and digested by the fish and is used in the fish metabolism supplying energy and nourishment for growth and other physiological processes. Oxygen (O_2) enters through the gills to produce energy and to break down protein, whereby carbon dioxide (CO_2) and ammonia (NH_3) are produced as waste products. The indigestible part of the feed is excreted into the water as faeces, termed suspended solids (SS) and dissolved organic matter. Carbon dioxide and ammonia are excreted

Figure 2.2 Eating feed and using oxygen results in fish growth and excretion of waste products, such as carbon dioxide, ammonia and faeces

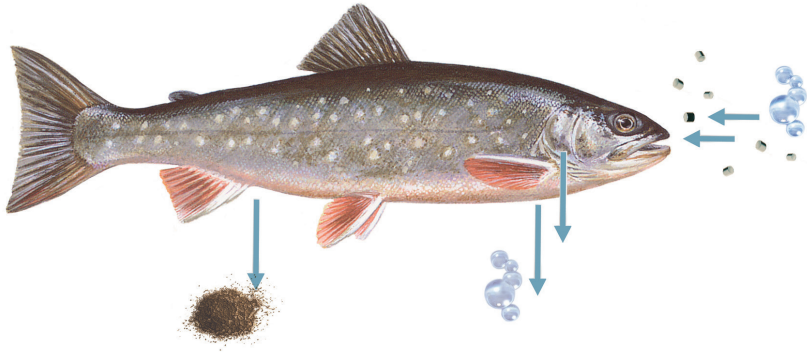

from the gills into the water. Thus, fish consume oxygen and feed, and as a result the water in the system is polluted with faeces, carbon dioxide and ammonia.

Only dry feed is recommended for use in a recirculation system. The use of industrial fish in any form must be avoided as it will pollute the system heavily and infection with diseases is very likely. The use of dry feed is safe and has the advantage of being designed to meet the exact biological needs of the fish species. Dry feed is delivered in different pellet sizes suitable for any fish size, and the ingredients in dry fish feed can be combined to develop special feeds for fry, brood stock, grow-out, etc.

In a recirculation system, a high utilization rate of the feed is beneficial as this will minimise the amount of excretion products thus lowering the impact on the water treatment system. In a professionally managed system, all the feed added will be eaten keeping the amount of uneaten feed to a minimum. The feed conversion ratio (FCR), describes the weight of feed needed for every kilogram of fish produced. If this is improved the farmer gets a higher production yield with a lower impact on the filter system. Uneaten feed is a waste of resources and money, and results in an unnecessary load on the filter system. Feeds especially suitable for use in recirculation systems are available. The composition of such feeds aims at maximising the uptake of protein in the fish thus minimising the excretion of ammonia into the water. It is also an advantage if the faeces produced are solid rather than soluble as a larger part of the waste products will be removed already at the step of mechanical filtration. Solid faeces also reduce the amount of fine particles suspended in the water, resulting in cleaner and clearer system water.

Table 2.1 Ingredients and content of a trout feed suitable for use in a recirculation system

Pellet size	Fish size, gram	Protein	Fat
3 mm	50–100	43%	29 %
4.5 mm	100–450	42 %	30 %
6.5 mm	450–1000	41 %	31 %

Ingredients (%)	3.0 mm	4.5 mm	6.5 mm
Fishmeal	20	19	18
Fish oil	10	11	11
Rape seed oil	16	16	17
Haemoglobin meal	11	11	11
Peas	5	5	5
Soya	10	11	11
Wheat	12	11	11
Wheat gluten	5	5	5
Other protein concentrates	10	10	10
Vitamins, minerals, etc.	1	1	1

Source: BioMar.

Components in a recirculation system

Fish tanks

Table 2.2 Different tank designs give different properties and advantages

Tank properties	Circular tank	D-ended raceway	Raceway type
Self-cleaning effect	5	4	3
Low residence time of particles	5	4	3
Oxygen control and regulation	5	5	4
Space utilization	3	4	5

Rating 1–5, where 5 is the best.

The environment in the fish rearing tank must meet the needs of the fish, both in respect of water quality and tank design. Choosing the right tank design, such as size and shape, water depth, self-cleaning ability, etc. can have a considerable impact on the performance of the species reared.

If the fish is bottom dwelling (turbot, sole or other flatfish), the need for tank surface area is most important, and the depth of water and the speed of the water current can be lowered. Pelagic living species such as salmonids will benefit from larger water volumes and show improved performance at higher speeds of water.

In a circular tank – or in a square-shaped tank – the water moves in a circular pattern making the whole water column of the tank move around the centre. The organic particles have a relatively short residence time of a few minutes, depending on tank size, due to this hydraulic pattern that gives a self-cleaning effect. A vertical inlet with horizontal adjustment is an efficient way of controlling the current in such tanks.

In a raceway the hydraulics have no positive effect on the removal of the particles. On the other hand, if a fish tank is stocked efficiently with fish, the

Figure 2.3 An example of octagonal tank design in a recirculation system saving space yet achieving the good hydraulic effects of the circular tank

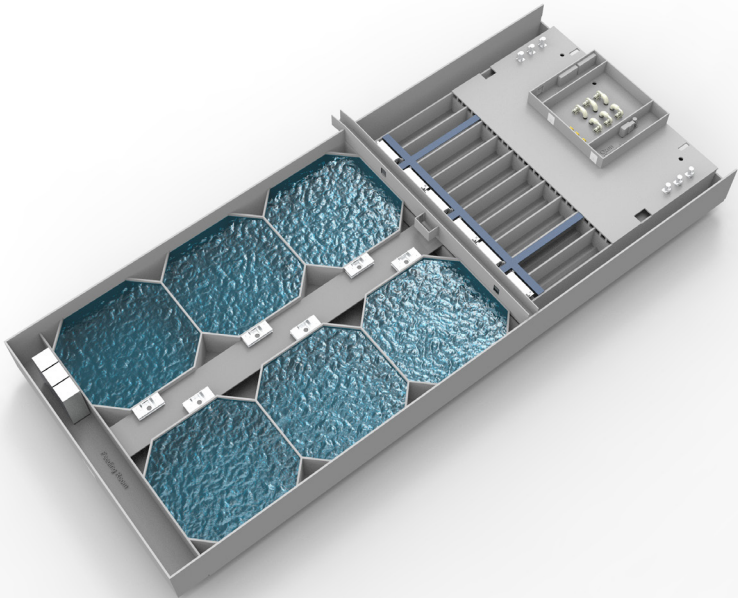

Source: AKVA group.

self-cleaning effect of the tank design will depend more on the fish activity than on the tank design. The inclination of the tank bottom has little or no influence on the self-cleaning effect, but it will make complete draining easier when the tank is emptied.

Circular tanks take up more space compared to raceways, which adds to the cost of constructing a building. By cutting off the corners of a square tank an octagonal tank design appears, which will give better space utilization than circular tanks, and at the same time the positive hydraulic effects of the circular tank are achieved (see Figure 2.3). It is important to note that construction of large tanks will always favour the circular tank as this is the strongest design and the cheapest way of making a large tank.

A hybrid tank type between the circular tank and the raceway called a “D-ended raceway” (see Figure 2.4) combines the self-cleaning effect of the circular tank with the efficient space utilization of the raceway. However, in practice this type of tank is seldom used, presumably because the design and installation of the tank and in- and outlets are more complex.

Sufficient oxygen levels are important for the welfare of the fish and are usually kept high by increasing the oxygen level in the inlet water to the tank. Most

Figure 2.4 Circular tank, D-ended raceway, and raceway type

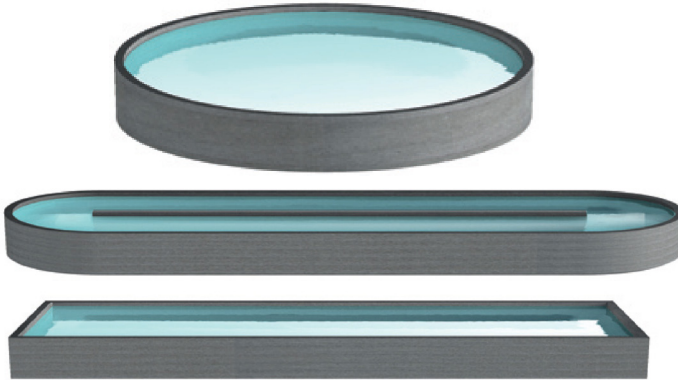

farms will have systems installed for dissolving pure oxygen into the process water to secure the availability of sufficient oxygen levels. The systems work using a chamber, such as an oxygen cone, in which water and oxygen is mixed under pressure to reach a high oxygen saturation. Direct injection of pure oxygen in the tank using diffusers is also possible, but the efficiency is lower and the equipment more costly. Direct oxygen injection in tanks is primarily used for emergency situations and often connected to a magnetic valve that releases the oxygen when the power fails.

Control and regulation of oxygen levels in circular tanks or similar is relatively easy because the water column is constantly mixed making the oxygen content almost uniform everywhere in the tank. This means that it is quite easy to keep the desired oxygen level in the tank. An oxygen probe placed near the tank outlet will give a good indication of the oxygen available. The time it takes for the probe to register the effect of oxygen being added to a circular tank will be relatively short. The probe must not be placed close to where pure oxygen is injected or where oxygen rich water is added.

In a raceway, however, the oxygen content will always be higher at the inlet and lower at the outlet, which also gives a different environment depending on how the fish are swimming. The oxygen probe for measuring the oxygen content of the water should always be placed in the area with the lowest oxygen content, which is near the outlet. This downstream oxygen gradient will make the regulation of oxygen more difficult as the time lag from adjusting the oxygen up or down at the inlet to the time this is measured at the outlet can be up to an hour. This situation may cause the oxygen to go up and down all the time instead of fluctuating around the selected level. However, installation of modern oxygen control systems using algorithms and time constants will prevent these unwanted fluctuations.

Tank outlets must be constructed for optimal removal of waste particles and fitted with screens with suitable mesh sizes that prevent fish from escaping and allowing dirt to pass through. Also, tank outlets should be constructed for easy removal of dead fish during the daily work routines.

In general, all tanks should be fitted with an oxygen sensor for constant information of oxygen availability and to give an alarm if levels drop to hazardous levels. For emergency situations it should be possible to inject oxygen directly into each tank using a diffuser placed at the tank bottom.

The water temperature is most often monitored using the oxygen probe as this normally comes with an integrated temperature sensor. Because of the high circulation rate in the RAS the water temperature is more or less the same in all tanks.

Fish tanks can also be fitted with a water level sensor to indicate if, e.g. levels are too low. Water level sensors are available in sophisticated versions for monitoring exact water levels. Such devices are used when fish are handled for grading, vaccination or harvesting where the water level needs to be taken down gradually. A set-point is selected, and a pump system will adjust the water to the required level.

Figure 2.5 Drumfilter

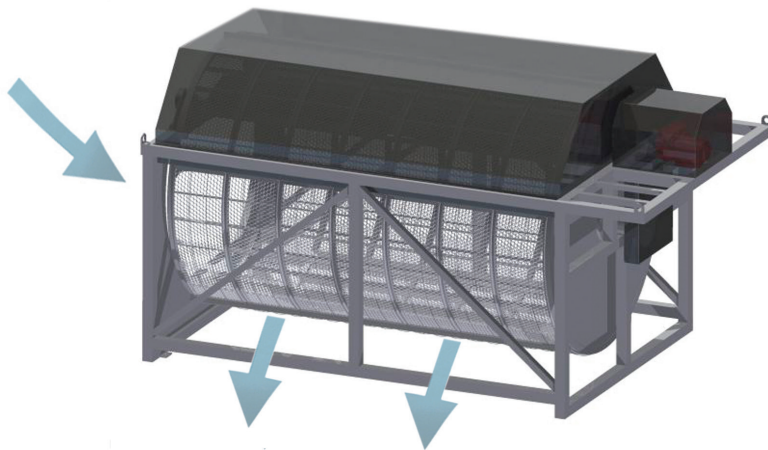

Water is filtered through a rotating drum equipped with a microscreen fitted with a filter cloth (20–100 microns).

Source: CM Aqua.

Mechanical filtration

Mechanical filtration of the outlet water from the fish tanks has proven to be the most practical solution for removal of the organic waste products. Today, almost all recirculated fish farms filter the outlet water from the tanks in a so called microscreen fitted with a filter cloth of typically 20 to 100 microns. The drumfilter is by far the most commonly used type of microscreen, and the design ensures gentle removal of particles.

Function of the drumfilter:

1. Water to be filtered enters the drum.
2. The water is filtered through the drumfilter cloth. The difference in water level inside/outside the drum is the driving force for the filtration.
3. Solids are trapped on the filter cloth and lifted to the backwash area by the rotation of the drum.
4. Water from rinse nozzles is sprayed from the outside of the filter cloth. The rejected organic material is washed out of the cloth into the sludge tray.
5. The sludge flows together with water by gravity out of the filter escaping the RAS for further treatment (see Chapter 6).

Microscreen filtration has the following advantages:

- Reduction of the organic load on the biofilter
- Making the water clearer as organic particles are removed from the water
- Improving conditions for nitrification of the biofilter as it does not clog
- Stabilising effect on the biofiltration processes

Biological treatment

Not all the organic matter is removed in the mechanical filter, the finest particles will pass through together with dissolved compounds such as phosphate and nitrogen. Phosphate is an inert substance, with no toxic effect, but nitrogen in the form of free ammonia (NH_3) is toxic and needs to be transformed in the biofilter to produce harmless nitrate. The breakdown of organic matter and ammonia is a biological process carried out by bacteria in the biofilter. Heterotrophic bacteria oxidise the organic matter by consuming oxygen and producing carbon dioxide, ammonia and sludge. Nitrifying bacteria convert ammonia into nitrite (NO_2^-) and finally to nitrate (NO_3^-). The efficiency of biofiltration depends primarily on:

- The water temperature in the system
- The pH level in the system

To reach an acceptable nitrification rate, water temperatures should be kept within 10 °C to 35 °C (optimum around 30 °C) and pH levels between 7 and 8. The water temperature in the RAS will most often depend on the species reared and is as such not adjusted to reach the most optimal nitrification rate in the biofilter, but to give optimal levels for fish growth. Regulation of pH in relation to biofilter efficiency is however important as lower pH level reduces the efficiency of the biofilter. The pH should therefore be kept above 7 in order to reach a high rate of the bacterial nitrifying process. On the other hand, increasing pH will result in an increasing amount of free ammonia (NH₃), which will enhance the toxic effect. The aim is therefore to find the balance between these two opposite directions of adjusting the pH. A recommended adjustment point is between pH 7.0 and pH 7.5.

Two major factors affect the pH in the water recirculation system:

- The production of CO₂ from the fish and from the biological activity of the biofilter
- The acid produced from the nitrification process

Result of nitrification:

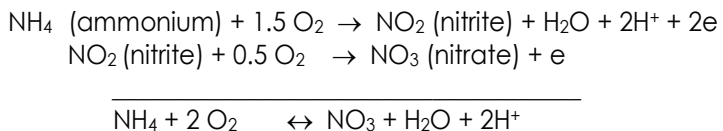

CO₂ is removed by aeration of the water, whereby degassing takes place. This process can be accomplished in several ways as described later in this chapter.

The nitrifying process produces acid (H⁺) and the pH level falls. In order to stabilize the pH, a base must be added. For this purpose, lime or sodium hydroxide (NaOH) or another base needs to be added to the water.

Fish excretes a mixture of ammonia and ammonium (Total Ammonia Nitrogen (TAN) = ammonium (NH₄⁺) + ammonia (NH₃)) where ammonia constitutes the main part of the excretion. The amount of ammonia in the water depends however on the pH level as can be seen in Figure 2.8, which shows the equilibrium between ammonia (NH₃) and ammonium (NH₄⁺).

Figure 2.6 The equilibrium between ammonia (NH_3) and ammonium (NH_4^+) at 20 °C.

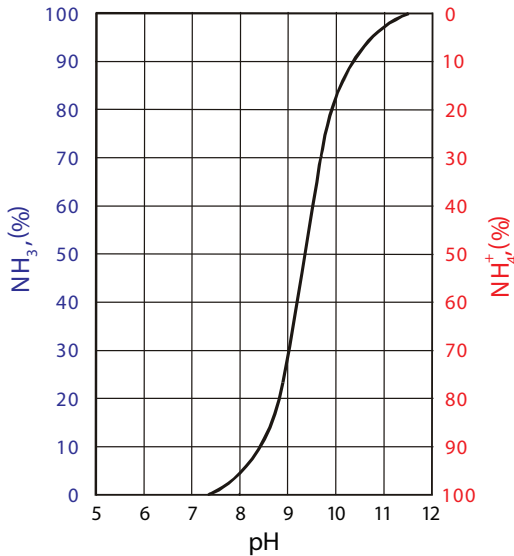

The toxic ammonia is absent at pH below 7, but rises rapidly as pH is increased.

Figure 2.7 The relation between measured pH and the amount of TAN available for breakdown in the biofilter, based upon a toxic ammonia concentration of 0.02 mg/L at 15 °C

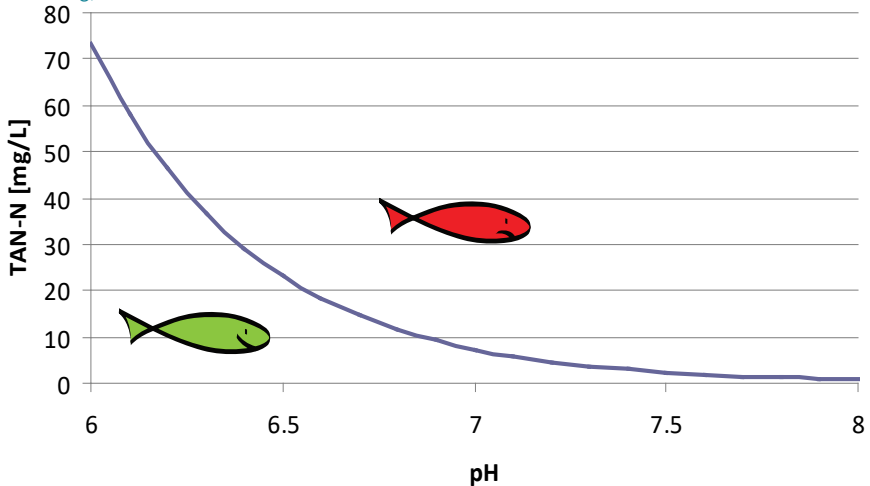

TAN levels above the line are toxic to fish.

In general, ammonia is toxic to fish at levels above 0.02 mg/L. Figure 2.7 shows the maximum concentration of TAN to be allowed at different pH levels if a level below 0.02 mg/L of ammonia is to be ensured. The lower pH levels minimise the risk of exceeding this toxic ammonia limit of 0.02 mg/L, but the fish farmer is recommended to reach a level of minimum pH 7 in order to reach a higher biofilter efficiency. Unfortunately, the total concentration of TAN to be allowed is thereby significantly reduced as can be seen in Figure 2.7. Thus, there are two opposite working vectors of the pH that the fish farmer must take into consideration when tuning his biofilter.

Nitrite (NO_2^-) is formed at the intermediate step in the nitrification process, and is toxic to fish at levels above 2.0 mg/L. If fish in a recirculation system are gasping for air, although the oxygen concentration is fine, a high nitrite concentration may be the cause. At high concentrations, nitrite is transported over the gills into the fish blood, where it obstructs the oxygen uptake. By adding salt to the water, reaching as little as 0.3 ‰ (ppt), the uptake of nitrite is inhibited.

Nitrate (NO_3^-) is the end-product of the nitrification process, and although it is considered harmless, high levels (above 100 mg/L) seem to have a negative impact on growth and feed conversion. If the exchange of new water in the system is kept very low, nitrate will accumulate to unacceptable levels. One way to avoid the accumulation is to increase the exchange of new water, whereby a high concentration is diluted to a lower and trouble-free level.

On the other hand, the idea of recirculation is saving water, and in some instances water saving is a major goal. Under such circumstances, nitrate concentrations can be reduced by de-nitrification. Under normal conditions, a water consumption of more than 300 litres of new water per kg feed used in the RAS is sufficient to dilute the nitrate concentration. Using less water than 300 litres per kg feed makes the use of denitrification worth considering.

The most predominant denitrifying bacteria is called *Pseudomonas*. An anaerobic (no oxygen) process reduces nitrate to atmospheric nitrogen. In fact, this process removes nitrogen from the water into the atmosphere, whereby the load of nitrogen into the surrounding water environment is reduced. The process requires an organic source (carbon), for example wood alcohol (methanol) that can be added to a denitrification chamber. In practical terms 2.5 kg of methanol is needed for each kg nitrate denitrified.

Most often the denitrification chamber is fitted with biofilter media designed with a residence time of 2–4 hours. The flow must be controlled to keep outlet oxygen concentration at app. 1 mg/L. If oxygen is completely depleted the de-nitrification process is less effective, and there is an added risk of extensive production of hydrogen sulphide (H_2S) which smells of rotten eggs. Hydrogen sulphide is extremely toxic to fish and must be avoided in the RAS. Production of sludge in the denitrification chamber can be quite high, and the unit must be back-washed frequently.

Figure 2.8 Example of moving bio-media on left and fixed bio-media on right

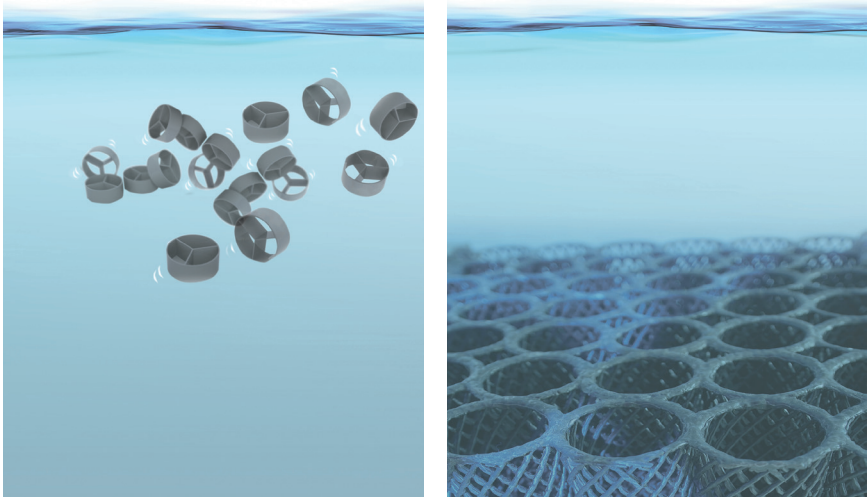

The moving bio-media shown may also be used in fixed bed designs.

Biofilters are typically constructed using plastic media with a high surface area per cubic metre (m^3) of biofilter. The bacteria will form a thin film on the media thereby occupying an extremely large surface area (compared to the size of the bio-media). The aim of a well-designed biofilter is to reach as high a surface area as possible per m^3 without packing the biofilter so tight that it gets clogged with organic matter under operation. In fixed bed biofilters it is therefore important to have a high percentage of free space for the water to pass through and to have a good overall flow through the biofilter together with a sufficient back-wash procedure. Such back-wash procedures must be carried out at sufficient intervals – once a week or month depending on the load and design of the filter. Compressed air is used to create a little turbulence in the filter whereby organic matter is ripped off. The biofilter is by-passed while the washing procedure takes place, and the dirty water in the filter is drained off and discharged before the biofilter is connected to the system again.

Many biofilters used in recirculation today work as submerged units (under water at all time). In the fixed bed filter, the plastic media is fixed and not moving. The water runs through the media as a laminar flow to make contact with the bacterial film. In the moving bed filter, the plastic media moves around in the water inside the biofilter by a current created by pumping in air. There is no significant difference in the turnover rate calculated per square metre (m^2) (filter surface area) between fixed and moving bed as the efficiency of the bacterial film in either of the two types of filter is more or less the same. In the fixed bed filter, however, fine organic particles are also removed as these substances adhere to

the bacterial film. The fixed bed filter will therefore act also as a fine mechanical filtration unit, also called microparticle filtration, removing microscopic organic material and leaving the water very clear. The moving bed filter will not have the same effect as the constant turbulence of water will make any adhesion impossible. On the other hand, moving bed filters are self-cleaning and do not need to be back-washed.

Figure 2.9 Moving bed (top) and fixed bed biofilters (bottom)

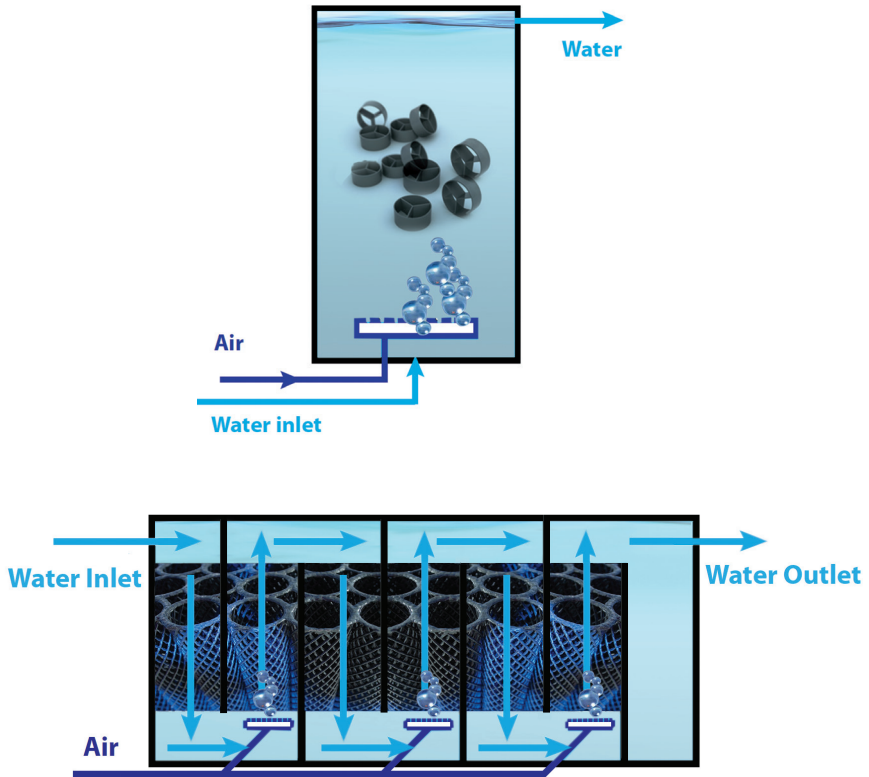

Both types of biofilters can be used in the same system, using the moving bed filter to avoid the trouble of back-washing, and the fixed bed to benefit from the effect of microparticle removal. Thus, there are several solutions for the final design of biofilter systems depending on farm size, species to be cultured, fish sizes, etc.

Degassing and aeration

Before the water runs back to the fish tanks accumulated gases must be removed to secure optimal conditions for the fish. This process is carried out by aeration of the recirculated water and is most often referred to as degassing. The RAS water contains elevated concentrations of carbon dioxide (CO_2) from the fish respiration and from the bacterial activity in the biofilter. Free nitrogen (N_2) at super-saturated levels (more than 100 percent) may also occur due to different pressures in the recirculation process. Uncontrolled accumulation of carbon dioxide and nitrogen gas levels will have detrimental effects on fish welfare and growth

Hydrogen sulfide (H_2S) is also a gas that must be removed from the water. As mentioned earlier hydrogen sulphide gas can be produced under anaerobic conditions. This is especially risky in saltwater systems as saltwater contains much more sulphate than freshwater. Fish will be affected and likely killed if hydrogen sulphide is generated and circulated in the system. Thus, a RAS must be designed to avoid sludge accumulation and to prevent the formation of hydrogen sulphide.

Degassing can be accomplished by simple aeration by blowing air into the water whereby the turbulent contact between the air bubbles and the water drives out the gases. This underwater aeration makes it possible to move the water at the same time, for example if an aeration well system is used (see Figure 2.10).

Figure 2.10 Aeration well system using the air-lift principle



Air injected at the bottom of the well drags water through the farm. At the same time the water is aerated and degassed.

Figure 2.11 Photo and drawing of a trickling filter wrapped in a blue plastic liner to eliminate splashing on the floor

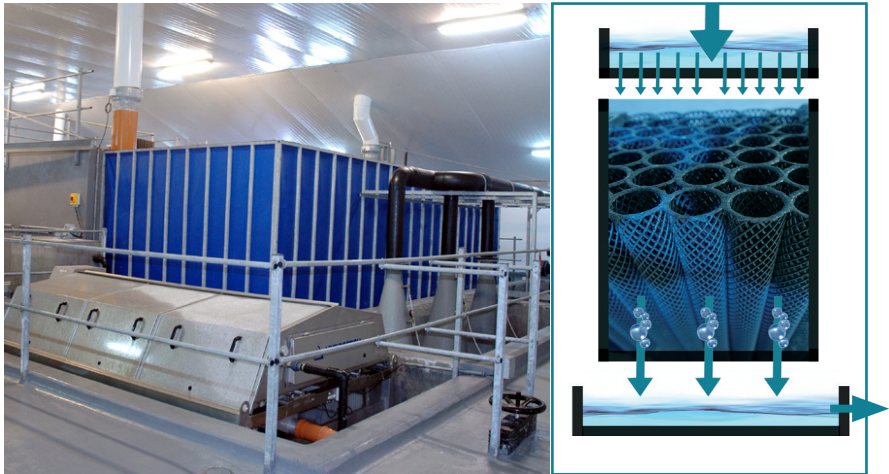

The aeration/degassing process is also called CO_2 -stripping.
Source: Billund Aquaculture, Denmark.

Instead of simple water aeration, a trickling system can be used. In the trickling filter gases are stripped off by physical contact between the water and plastic media stacked in a column. Water is led to the top of the filter over a distribution plate with holes and flushed down through the plastic media to maximise turbulence and contact, the so-called stripping process.

Degassing using vacuum technology can supplement the degassing methods mentioned above. Some fish species are less tolerant to high CO_2 levels and especially small fish or fish larvae can be very sensitive to supersaturation (levels above 100 percent saturation) of nitrogen. Vacuum degassing is used to bring down carbon dioxide and nitrogen to lower levels than those achieved by simple aeration, or trickling, where removal of gas to a lower level than 100 percent saturation is impossible. Using vacuum makes it possible to drag out gas to levels less than 100 percent saturation. A vacuum degasser is normally installed to take a smaller part of the main RAS flow whereby the vacuum degassed water is mixed into the main flow resulting in a lower gas saturation overall.

Figure 2.12 A vacuum degasser is used for dragging out gasses in the water to reach lower gas saturations than using traditional degassing technology. Vacuum degassing is primarily used for juvenile fish that are often more sensitive to gas supersaturation

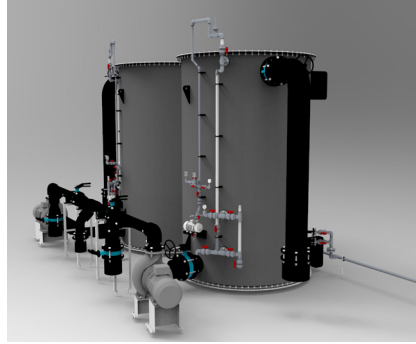

Oxygenation

The aeration process of the water is the same physical process as degassing or stripping, and adds oxygen to the water through simple exchange between the gases in the water and the gases in the air. The equilibrium of oxygen in water is 100 percent saturation. When the water has been through the fish tanks, the oxygen content has been lowered because of fish respiration, typically down to around 70–80 percent, and the content is reduced further in the biofilter. Aeration of this water will typically bring the oxygen saturation up to around 90 percent, in some systems 100 percent can be reached. However, oxygen saturation higher than 100 percent in the inlet water to the fish tanks is often preferred in order to have sufficient oxygen available for a high and stable fish growth. If saturation levels are needed above 100 percent a system using pure oxygen must be in force.

Figure 2.13 Oxygen cone for dissolving pure oxygen at high pressure and a close-up of a sensor (probe) for measuring the oxygen saturation of the water



Source: Oxyguard International.

Pure oxygen is often delivered by a lorry and stored in a holding tank on site in the form of liquid oxygen (LOX) but can also be produced on the farm in an oxygen generator. There are several ways of making super-saturated water with oxygen contents reaching 200–300 percent. Typically, high pressure oxygen cone systems or low head oxygen systems, such as oxygen platforms are used. The principle is the same: Water and pure oxygen are mixed under pressure whereby the oxygen is forced into the water. In the oxygen cone the pressure is accomplished using a water pump creating a high pressure of typically around 1.4 bar in the cone. However, pumping water under pressure into the oxygen cone consumes a lot of electricity. In the oxygen platform the pressure is much lower, typically down to about 0.1 bar and water is simply pumped through the box mixing water and oxygen. The high pressure solution uses a part of the circulating water in a separate loop for oxygen enrichment, whereas the low pressure solution uses all the circulating water in the RAS.

Whatever oxygenation method used, the process should be controlled with the help of oxygen measurement. Most often an oxygen probe is placed in the fish tank to give a feedback signal to the oxygenation control system whether to increase or reduce the volume of oxygen injected.

Figure 2.14 Oxygen platform for dissolving pure oxygen at low pressure while pumping water around in the farm. The system typically increases the level of dissolved oxygen to just above 100 percent depending on flow rates and farm design

Source: FREA Aquaculture Solutions.



Ultraviolet light

Ultraviolet light (UV) treatment works by applying light in wavelengths that damage the DNA in biological organisms. In aquaculture pathogenic bacteria and single-celled organisms are targeted. The treatment has been used for medical purposes for decades and does not impact the fish as UV treatment of the water is applied outside the fish production area in a UV secured enclosure. A high UV radiation efficiency in a RAS is best achieved at high UV transmission rates (UVT). The clearer the water the higher the UVT. Transmission rates of UVT 90 percent or more is recommended to reach a high killing rate, although UV treatment will also have an effect at lower UVTs. Mechanical filtration through a drumfilter followed by fixed bed biofiltration that includes the effect of microparticle removal will create clear water (low turbidity) sufficient to gain an efficient UV treatment.

The UV dose can be expressed in several different units. One of the most widely used is millijoule per square centimetre (mJ/cm^2).

To kill most types of fish pathogenic bacteria will require up to $20 \text{ mJ}/\text{cm}^2$ at 90 percent killing rate. Killing the most common fungus in RAS called *Saprolegnia* will require $40 \text{ mJ}/\text{cm}^2$ if suspended in the water as hypha or spores, and $230 \text{ mJ}/\text{cm}^2$ if at the fungus stage. To kill parasites, such as *Ich*, *Trichodina* or *Costia* will require levels as high as $300 \text{ mJ}/\text{cm}^2$ or more.

UV lighting used in aquaculture must work under water to give maximum efficiency, lamps fitted outside the water will have little or no effect because of water surface reflection. Caution must be paid to ensure that no UV light is directly shining on people.

Figure 2.15 Closed and open UV treatment systems



For installation in a closed piping system and in an open channel system respectively. Source: ULTRAAQUA

Ozone

The use of ozone (O_3) in fish farming has been criticised because the effect of over-dosing can cause severe injury to the fish. In farms inside buildings, ozone can also be harmful to the people working in the area as they may inhale too much ozone. Thus, correct dosing and monitoring of the ozone concentration together with correct design and proper ventilation is crucial to reach a positive and safe result.

Ozone treatment is an efficient way of destroying unwanted organisms by the heavy oxidation of organic matter and biological organisms. In ozone treatment technology, micro particles are broken down into molecular structures that will

bind together again and form larger particles, a form of coagulation. These larger particles are then caught in the RAS filter systems instead of passing through as microscopic particles. This technology is also referred to as water polishing as it makes the water clearer and reduces suspended solids and bacteria adhering to these. This is especially suitable in hatchery and fry systems growing small fish sensitive to micro particles and bacteria in the water. This kind of water conditioning is also becoming increasingly popular in grow-out systems.

Figure 2.16 Ozone generator.



Source: Wedeco/Xylem

pH regulation

The nitrifying process in the biofilter produces acid making the pH level drop over time. To maintain a stable pH in the RAS, a base must be added to the water. In most RAS the pH ranges between 6.5 and 7.5 often balancing around pH 7.0, because higher pH from this mean will favour nitrification in the biofilter and lower pH will favour removal of CO₂ in the degasser. Most commonly sodium hydroxide (NaOH), also called lye or caustic soda, is used for pH regulation. Alternatively calcium hydroxide (Ca(OH)₂), commonly known as slaked lime can be used. If calcium hydroxide is used, a mixing station must be installed to produce lime water that can be added through an automatic dosage system regulated by a pH-metre with a feedback impulse to a dosage pump. The same principle can be applied using sodium hydroxide, which comes in liquid form in pallet tanks easier to handle and less messy as there is no need for a mixing station. Lime and caustic soda are alkalines that can severely burn eyes and skin.

Figure 2.17 Dosage pump for pH regulation by preset dosing of NaOH. The pump can be connected to a pH sensor for fully automatic regulation of pH level



Safety precautions must therefore be taken, and safety glasses and gloves must be worn while handling these and other acids and bases.

Alkalinity and hardness

Alkalinity and hardness are often confused due to some similarities that they share, e.g. both parameters are measured in mg/L calcium carbonate (CaCO_3) and the concentration of alkalinity and hardness in a water sample can sometimes be almost identical. However, hardness expresses the sum of metal ions in the water whereas alkalinity is a measure of the pH buffering capacity or the ability to neutralize acid.

In some areas the make-up water used in the RAS is extremely hard (> 300 mg/L) causing problems with calcification of valves, pipes and heat exchangers. In other areas the water is very soft (0–75 mg/L) and must be “hardened” when used in RAS, because low alkalinity can interfere with pH stability, nitrification rate and CO_2 -stripping efficiency. The alkalinity in RAS water should preferably range between 70–200 mg/L CaCO_3 for the fish farmer to have sufficient and safe control of his water. The alkalinity can be increased and controlled by adding calcium to the system using e.g. sodium bicarbonate (NaHCO_3), known as baking soda, or calcium hydroxide (Ca(OH)_2), known as slaked lime.

It is worth mentioning that the nitrification in the biofilter consumes alkalinity, in fact 7 g of alkalinity is consumed for every gram of ammonia converted into nitrate. In contrast, the de-nitrification process produces roughly 3.5 g as CaCO_3 per gram of nitrate converted into nitrogen gas (N_2).

The CO_2 stripping in the degasser also consumes alkalinity as carbon is continuously removed from the system by this process.

*Figure 2.18 Effective and safe handling of chemicals for pH and alkalinity adjustment is key in efficient farm operation. A solution for dust-free emptying of bigbags containing alkalines such as slaked lime, baked soda or lye is recommended
Source: Tekfa A/S.*



Careful monitoring and adjustment of alkalinity is important to keep a stable water environment. Some RAS managers prefer the use of calcium hydroxide ($\text{Ca}(\text{OH})_2$) to regulate pH and alkalinity using the one and same chemical, whereas others prefer to use sodium hydroxide (NaOH) for pH adjustment and add sodium bicarbonate (NaHCO_3) or calcium hydroxide as a supplement if needed.

Water temperature regulation

Maintaining an optimal water temperature in the culture system is very important as the growth rate of the fish is directly related to the water temperature. Adjusting the volume of intake water used is a fairly simple way of regulating the temperature from day to day. However, heating and cooling systems have become more popular to use. In an indoor recirculation system, the heat will slowly build up, because energy in the form of heat is released from the fish's metabolism and the bacterial activity in the biofilter. Heat from friction in the pumps and the use of other electrical installations will also generate heat. Too high water temperatures are therefore more often a problem in an intensive recirculation system than too low temperatures.

The design and dimensioning of the heating/cooling system depends on local weather conditions, most importantly the minimum and maximum air temperatures and humidity. In addition, it is worth investigating if there are any

local resources in the form of waste heat, geothermal energy, cool seawater or groundwater available for use. The use of such sources, if applicable, can make significant savings to the heating/cooling process. If no such resources are available, chillers, heat pumps or boilers must be used.

In many instances the search for a cooling solution ends by installing a common air to water chiller that is using electrical power to produce cold water for the RAS. The chiller brings cool water to a heat exchanger connected to the RAS circuit.

In cold climates heating of the RAS water can be necessary, especially in systems starting with a small biomass of fish producing little metabolic energy. The heat for the RAS can be produced using an oil or gas boiler connected to a heat exchanger to heat the recirculated water. Heat pumps are an environmentally friendly alternative heating solution, these pumps can utilize energy for heating using a water resource or the surrounding air.

Another way of lowering heating cost can be achieved by recovering energy from the RAS discharge water using a heat exchanger. The energy is transferred to the cold incoming intake water. This is achieved by passing both streams into the

Figure 2.19 Schematic illustration of the water temperature regulation in a RAS

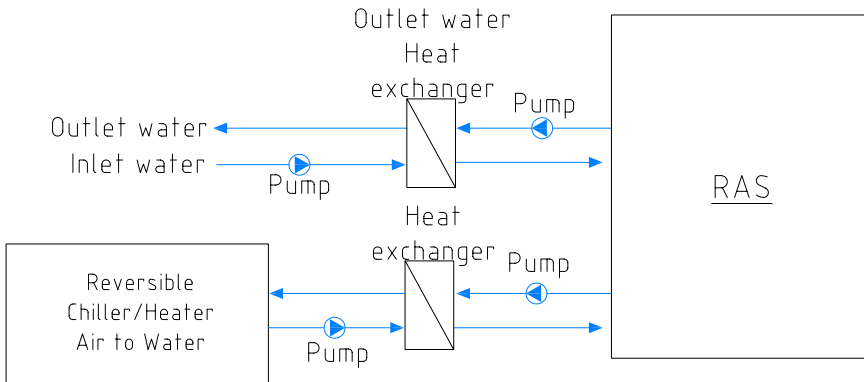

A reversible air to water chiller/heater is connected to a heat exchanger that transfers heat or cooling to the RAS process water. In addition, a heat exchanger can be connected to the outlet water for reuse and transfer heat or cooling to the intake water.

heat exchanger where the warm outlet water will heat up the cold intake water without mixing the two streams.

Pumps

Different types of pumps are used for circulating the process water in the system. Pumping normally requires a substantial amount of electricity. Thus, low lifting heights and efficient and correctly installed pumps are important to keep running costs at a minimum.

The lifting of water should preferably occur only once in the system, whereby the water runs by gravity all through the system back to the pump sump. Pumps should be placed after the mechanical filtration to avoid breaking the solids coming from the fish tanks. Most often pumps are placed either in front or after of the biofiltration and degassing area to build up pressure before water is running into the fish tanks and back to the mechanical filtration before taking another round in the system.

Calculation of the total lifting height for pumping is the sum of the actual lifting height and the pressure losses in pipe runs, pipe bends and other fittings. This is also called the dynamic head. If water is pumped through a submerged biofilter

Figure 2.20 Lifting pumps type KPL for efficient lifting of large amounts of water

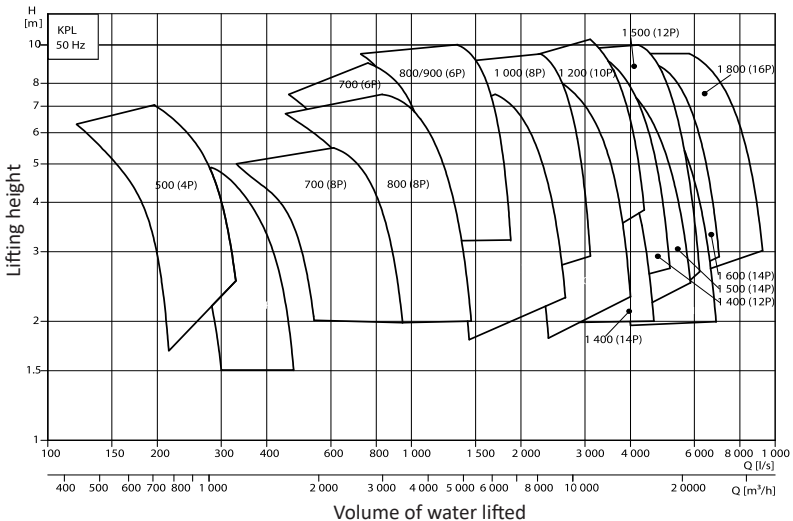

Lifting pumps are often used for pumping the main flow in the recirculation system. Correct selection of pump is important to keep the running costs down. Frequency control is an option to regulate the exact flow needed depending on the fish production. H is the lifting height and Q is the volume of water lifted. Source: Grundfos.

Figure 2.21 Centrifugal pumps type NB for pumping water when high pressure or high lifting heights are needed

NB, 4-pole

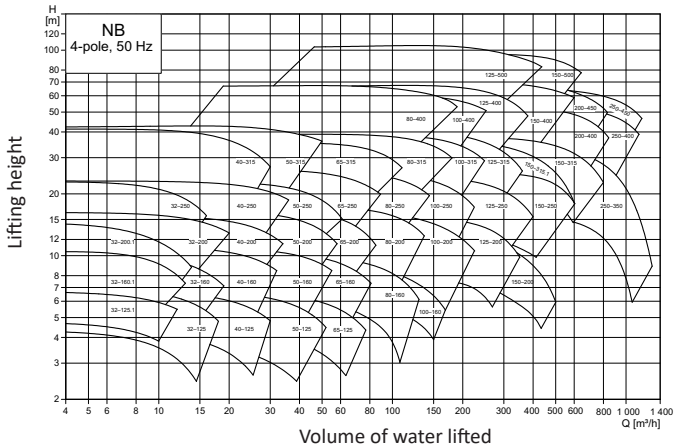

The range of centrifugal pumps is wide, so these pumps are also efficiently used for pumping at lower lifting heights. Centrifugal pumps are often used in recirculation systems for pumping secondary flows as for example flows through UV systems and for generating a high pressure in oxygen cones. H is the lifting height and Q is the volume of water lifted.

Source: Grundfos.

before trickling down through the degasser, a counter pressure from the biofilter will also have to be accounted for. Details on fluid mechanics and pumps are beyond the scope of this guide.

Today, the total lifting height in many intensive recirculation systems is around 2–3 metres. Thus, using low-pressure pumps as the most efficient type for

Figure 2.22 Example of dry set-up for a main water pump

Source: Lykkegaard.

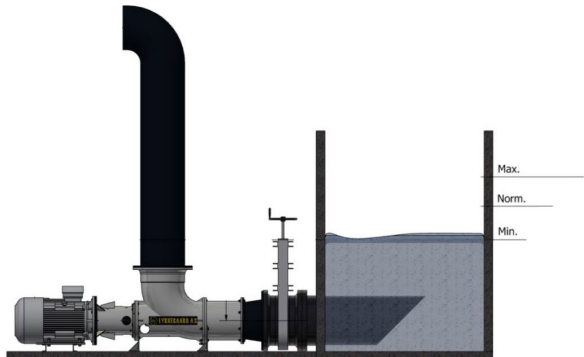

pumping the main flow around. However, the process of dissolving pure oxygen into the process water often requires centrifugal pumps as these pumps will create the required high pressure in the oxygen cone. In some systems, where the lifting height for the main flow is very low, the water is driven without the use of pumps, and instead air is blown into aeration wells. In these systems the degassing and the movement of water are accomplished in one process, which makes low lifting heights possible. This way of degassing and moving of water in one and same process is however not necessarily more efficient than that of separately pumping water and separately degassing the water, because the efficiency of each of the processes is most often designed and optimized extremely well on their own.

Monitoring, control and alarms

Intensive fish farming requires close monitoring and control of the production to maintain optimal conditions for the fish at all times. Technical failures can easily result in substantial losses. Thus, alarms are vital installations for securing the operation.

In many modern farms, a central control system can monitor and control oxygen levels, temperature, pH, water levels and pump functions. If any of the parameters moves out of the desired hysteresis values, a given start/stop process will solve the problem. If the problem is not solved automatically, an alarm will start. Automatic feeding can also be an integrated part of the central

Figure 2.23 An oxygen probe (OxyGuard) is calibrated in the air before being lowered into the water for on-line measurement of the oxygen content of the water (left)

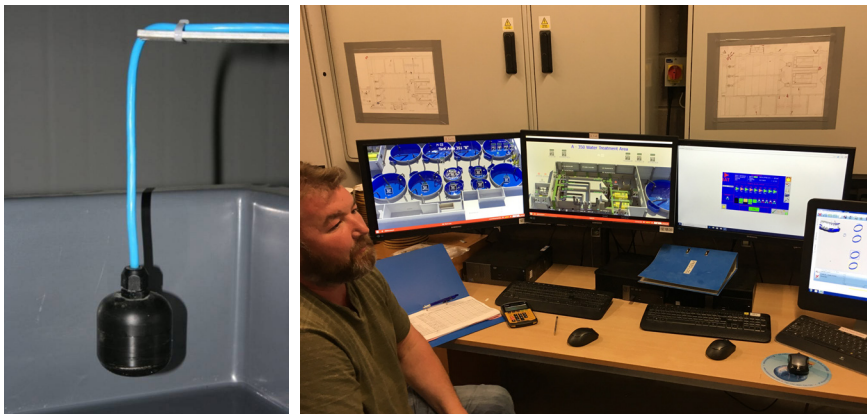

A typical desk of a modern fish farmer where surveillance can be computerized with a large number of measuring points and alarm controls (right).

control system. This allows the timing of the feeding to be coordinated precisely with a higher dosage of oxygen as the oxygen consumption rises during feeding. In less sophisticated systems, the monitoring and control is not fully automatic, and personnel will have to make several manual adjustments.

Whatever the case, no system will work without the surveillance of the personnel working on the farm. The control system must therefore be fitted with an alarm system, which will call the personnel if any major failures are about to occur. A reaction time of less than 20 minutes is recommended, even in situations where automatic back-up systems are installed.

Emergency system

The use of pure oxygen as a back-up is the number one safety precaution. The installation is simple, and consists of a holding tank for pure oxygen and a distribution system with diffusers fitted in all tanks. If the electricity supply fails a magnetic valve pulls back and pressurized oxygen flows to each tank keeping the fish alive. The flow sent to the diffusers should be adjusted beforehand, so that the oxygen in the storage tank in an emergency situation lasts long enough for the failure to be corrected in time.

To back up the electrical supply, a fuel driven electrical generator is necessary. It is very important to get the main pumps in operation as fast as possible, because ammonia excreted from the fish will build up to toxic levels when the water is not circulating over the biofilter. It is therefore important to get the water flow up and running within an hour or so.

Figure 2.24 Liquid oxygen (LOX) tank and an electrical emergency generator driven by diesel

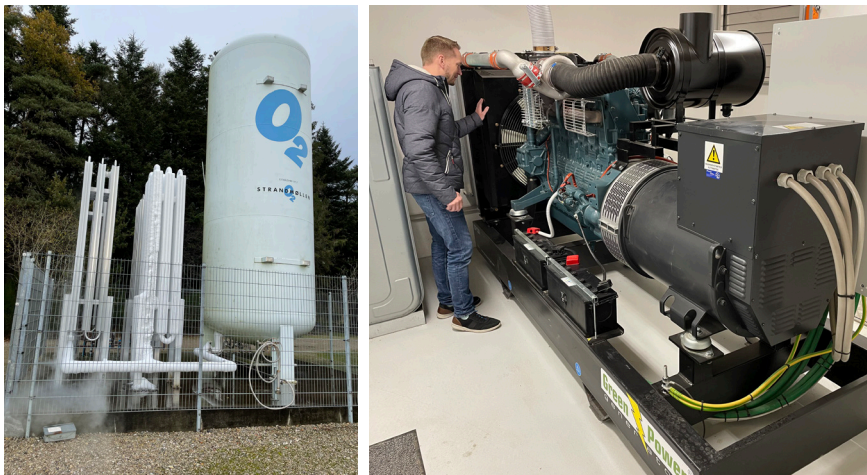

Intake water

Water used for recirculation should be sterilized before coming into the system to avoid any kind of diseases from entering/spreading. If a disease enters the RAS the recirculation process will spread the disease to all tanks often with disastrous effects on fish mortality. Most often a disease can be treated, but it will most likely still be in the system with the potential of a later outbreak. The only way to get completely rid of a disease will be to remove all fish and disinfect the whole system before re-stocking.

For the same reasons, intake water coming from a spring or a borehole is preferred to water coming from a river, lake or the sea where diseases are much more likely. Most water from the underground is disease free and it is also easier to treat water from the ground because it is most often clear and can be disinfected efficiently using ultraviolet light (UV). Water coming from rivers, lakes or the sea will require a more thorough cleaning and disinfection processes, because the water is most often dirty and holds organic material and other substances. The use of mechanical filtration and/or sand filtering followed by UV and/or ozone treatment are typical ways of securing clean and disinfected water for a RAS.

Figure 2.25 Example of intake water disinfection for treatment before use in the RAS

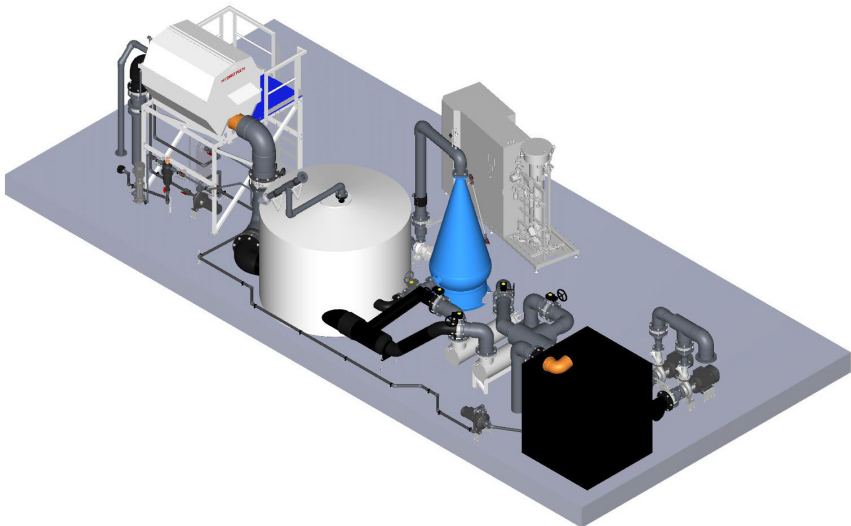

Water is filtered in a mechanical filter on left side before ozonation in a chamber at center. Water passes through two UV systems and finally enters the black holding tank.

Chapter 3: Fish species in recirculation

A recirculation system is a costly affair to build and also to operate. There is competition in all markets for fish and the production must be efficient to make a profit. Selecting the right species for production and constructing an efficient system is therefore of highest importance. Essentially, the aim is to sell the fish at a high price and at the same time keep the production cost at the lowest possible level.

Water temperature is one of the most important parameters when looking at the feasibility of fish farming. The reason is that fish are cold blooded animals. This means that fish have the same body temperature as the temperature of the water in which they swim. Fish do not regulate their body temperature like pigs, cows or other warm blooded animals.

Different fish species have different optimal temperatures for growth. Fish living in temperate climates, such as trout and salmon, have optimal growth rates at

Figure 3.1 Example of growth rate in Atlantic salmon at 8 ° and at 14 °C as a function of fish size.

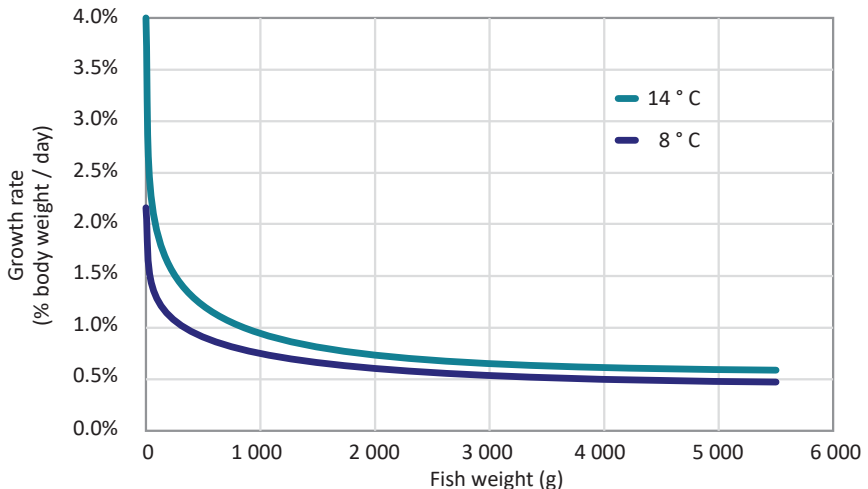

around 15 to 20 °C whereas fish living in tropical areas, such as tilapia and African catfish, have their optimal growth rates at around 30 °C. Fish also have upper and lower lethal temperature limits, and the farmer must be sure to keep the farmed fish within these limits or the fish will die.

The cost of reaching and maintaining the optimal water temperature all year round in a recirculation facility is money well spent. Keeping fish at optimal rearing conditions will give a much higher growth rate in comparison to the often sub-optimal conditions in the wild. Also, it is important to note that all the advantages of clean water, sufficient oxygen levels, etc. in a recirculation system have a positive effect on survival rate, fish health, etc., which in the end results in a high-quality product.

The feasibility of fish farming in a RAS depends on the size of the fish grown. At any given temperature, smaller fish have higher growth rates than larger fish. This means that small fish will gain more weight over the same time period than large fish – see Figure 3.1.

Small fish also utilise fish feed better than large fish (i.e they have a feed conversion rate (FCR) that is lower and thus more efficient than larger fish – see Figure 3.2). Growing faster and utilising feed more efficiently will of course have a positive influence on the production costs as these are lowered when calculated per kilogram of fish produced. However, the production of small fish is just one step in the whole production process through to marketable fish. Naturally, not all fish produced in fish farming can be small fish, and the potential for growing small fish is therefore limited. Nevertheless, when discussing what kind of fish to produce in recirculation systems, first and foremost will be small fish. It simply makes sense to invest in fry or fingerling production, because one gets higher value for money spent, when farming small fish. A good example is the salmon sector where cage farming depends on stocking small salmon (smolt) into net pens at sea to grow fish to market size (around 5 kg). The smolt size used to be around 100 g when stocked, but today smolt are often produced at sizes of 400 g – or more – to make full use of the growth potential in the RAS.

Growing large fish in recirculation systems, also called on-growing, is in general more expensive per kilogram produced than growing small fish. Although larger fish use less oxygen per kilogram growth, they use more feed because of their low utilisation ability. Feed is by far the highest operational cost in fish farming. Thus, feed is the most important cost factor to monitor and control.

So, when fish grow bigger, they grow slower, and they utilize the feed less optimally compared to the small fish and at the same time they take up a very large part of the volume of the system. The number of fish may be the same as when the fish were small, but the fish are now considerably larger and require more tank space, oxygen, and feed. Farming large fish compared to small fish becomes a matter of holding a large biomass of slow growers in the system for

Figure 3.2 Example of feed conversion rate (FCR) of Atlantic salmon in a RAS related to fish weight at 14 °C

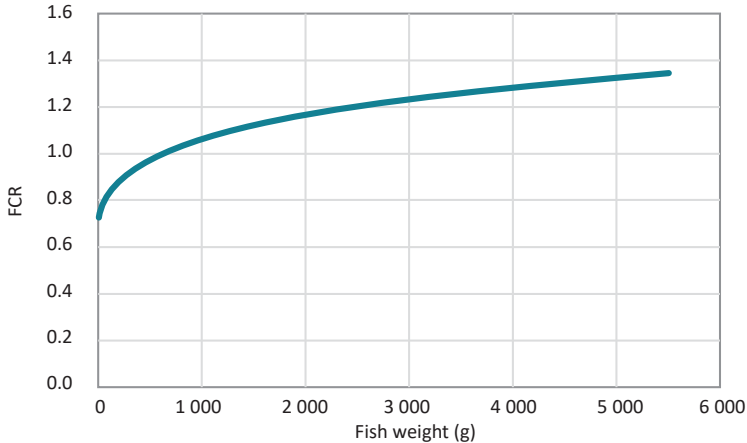

a considerable time before they are ready for harvest. Thus, investment costs as well as running costs are considerable larger when growing fish to market size.

Compared to other farmed animals, such as pigs, cattle, and chicken, there is a large variety of species in fish farming. In comparison, the market for pigs, cattle, or chicken is not diversified in the same way as fish. Consumers do not ask for different species of pigs, cattle, or chicken, they just ask for different cuts or sizes of cuts. When it comes to fish, the choice of species is wide, and many consumers are used to choosing from a large range of different fish, a situation which makes many different fish species interesting in the eyes of any fish farmer. Over the past few decades some hundred aquatic species have been introduced to aquaculture. Here, the rate of domestication of aquatic species is much faster than that of the domestication of plants and other animals.

Looking at the world production volume of farmed fish, the picture is however not in favour of a multi species output. From Figure 3.3 it can be seen that out of finfish species carps, tilapia and other freshwater species account for 47 percent of farmed fish. Salmon and trout form the next largest group of farmed finfish, but this category only consists of two species. The rest, under other, amounts to some ten species. One therefore has to realise that although there are plenty of species to be cultured, only a few of these go on to becoming real successes on a world-wide scale. However, this does not mean that all the new fish species introduced to aquaculture are failures. One just has to realise that the world production volume of new fish species is limited, and that the success and failures of growing these species depend very much on market conditions.

Figure 3.3 Distribution of global farmed seafood production in 2018

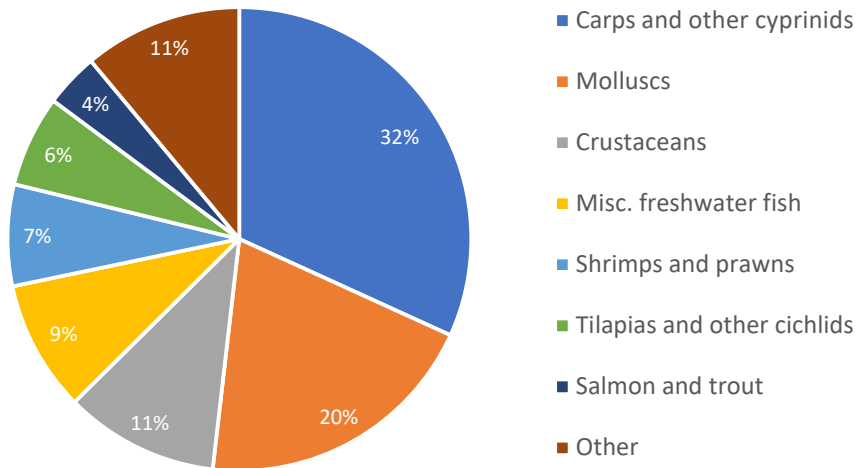

Source: FAO

Producing a small volume of a prestigious fish species may well be profitable as it fetches a high price. However, because the market for prestigious species is limited, the price may soon go down if production and thereby availability of the product rises. It can be very profitable to be the first and only one on the market with a new species in aquaculture. On the other hand, it is also a risky business with a high degree of uncertainty in both production and in market development.

When introducing new species in aquaculture it should also be remembered that we are bringing in wild species from nature. These species are being captured and reproduced in aquaculture to see if they will grow well and are fit for domestication. There are many things that will influence the success of domestication, such as overall behaviour, growth performance, genetic variation in growth rate, feed conversion rate, survival rate, early maturation, and disease susceptibility. Thus, it is very likely that the performance of fish from the wild does not correspond to the expectations of the fish farmer. Also, viruses in wild stocks can be brought in, of which some appear after several years breeding, resulting in a demoralising experience.

To give general recommendations on which species to culture in recirculation systems is not an easy task. Many factors influence the success of a fish farming business. For example, local building costs, cost and stability of electricity supply,

availability of skilled personnel, etc. Two important questions though should be asked before anything else is discussed: Does the fish species considered, have the ability to perform well in a recirculation facility, and secondly, is there a market for this species that will fetch a price high enough and at volumes large enough to make the project profitable?

The first question can be answered in a relatively simple manner. Seen from a biological point of view, any type of fish reared successfully in traditional aquaculture can just as easily be reared in recirculation. As mentioned, the environment inside the recirculated fish farm can be adjusted to match the exact needs of the species reared. The recirculation technology in itself is not an obstacle to any new species introduced. The fish will grow just as well, and often even better, in a recirculation unit. Whether it will perform well from an economic point of view is more uncertain as this depends on the market conditions, the investment, the production costs and the ability of the species to grow fast. Rearing fish with generally low growth rates, such as extreme cold water species, makes it difficult to produce a yearly output that justifies the investment made in the facility.

Whether market conditions are favourable for a given species reared in a recirculation system depends highly on competition from other producers. This is not restricted to local producers; fish trading is a global business and competition is global too. Trout farmed in Poland may well have to compete with catfish from Vietnam or salmon from farms in Norway as fish are easily distributed around the world at relatively low cost.





It has always been recommended to use recirculation systems to produce expensive fish because a high selling price leaves room for higher production costs. On the other hand, there is a tendency to use recirculation systems also for lower priced fish species such as portion sized trout, tilapia, or African catfish. This has most often to do with shortage of natural water and environmental concerns with regards to the discharge.

The Danish recirculation trout farm concept is a good example of recirculation technology entering a relatively low price segment such as the portion sized trout business. However, in order to be competitive, it is necessary for such production systems to be huge; operating in volumes from 1 000 tonnes and upwards. In the salmon business there is currently a very large interest in developing huge land-based salmon farms of around 10 000 tonnes as an alternative to the traditional cage farming technology. Most of these land-based projects are based on RAS technology not only to save water and limit the discharge, but with the aim of moving the production close to the consumers. Salmon RAS nearby big cities will deliver fresh fish and will spare the environment CO₂ emissions flying in fresh salmon from abroad.





The suitability of rearing specific fish species in recirculation depends on many different factors, such as the profitability, environmental concerns, and biological suitability. In the tables below fish species have been grouped into different categories depending on the commercial feasibility of growing them in a recirculation system.

It should be mentioned that for small fish the use of recirculation is always recommended, because small fish grow faster and are therefore particularly suited to a controlled environment until they have reached the size for on-growing.







Good biological performance and acceptable market conditions make the following fish interesting for production to market size in recirculation aquaculture:

Species	Current status	Market
Arctic char <i>(Salvelinus alpinus)</i> 14 °C 	Arctic char or cross breeds with brook trout has a long track record of growing well in cold water aquaculture.	Sold in specific markets at fair to good prices.
Atlantic salmon, smolt <i>(Salmo salar)</i> 14 °C 	Small salmon are called smolt. They are grown in freshwater before transfer to saltwater for grow-out. Smolts are raised in recirculation systems with great success.	The market for salmon smolt is usually very good. Demand is constantly increasing and the market for larger smolt is increasing.
Eel <i>(Anguilla anguilla)</i> 24 °C 	Proven successful species in recirculation. Cannot reproduce in captivity. Wild catch of fry (elvers) is necessary. It is an endangered species and it should be considered if farming is ethically justifiable.	Some buyers will refuse to buy because of threatened species status.
Grouper <i>(Epinephelus spp.)</i> 28 °C 	Saltwater fish grown primarily in Asia. Many different grouper species. Requires knowledge in spawning and larval rearing. Grow-out relatively straight forward.	Sold primarily in local markets at good prices in areas where production comes from many small producers.
Rainbow trout <i>(Oncorhynchus mykiss)</i> 16 °C 	Easy to culture. Recirculation in freshwater widely used from fry rearing up to portion size fish. Larger trout can also be grown in recirculation whether fresh or saltwater.	Relatively tough competition in most markets. Products need to be diversified.







Chapter 3: Fish species in recirculation

<p>Seabass/ Seabream (<i>Dicentrarchus labrax / Sparus aurata</i>) 24 °C</p> 	<p>Saltwater aquaculture fish in a highly developed cage farming industry. Larval phases require good rearing skills. Proven to grow well in recirculation.</p>	<p>Generally tough market conditions, but can fetch good prices for fresh fish in some local areas.</p>
<p>Sturgeon (<i>Acipenser spp.</i>) 22 °C</p> 	<p>Group of freshwater fish of many species relatively easy to culture. Skills required in different biological stages. Farming in recirculation systems is increasing.</p>	<p>Fair market conditions for meat. The caviar business seems to expand in high-end markets.</p>
<p>Turbot (<i>Scophthalmus maximus</i>) 17 °C</p> 	<p>Good skills required in broodstock and hatchery management. Grows very well in recirculation.</p>	<p>Generally tough international market conditions. Local market prices can be higher.</p>
<p>Whiteleg shrimp (<i>Penaeus vannamei</i>) 30 °C</p> 	<p>A most common shrimp species in aquaculture. Grow-out in recirculation systems has been proven successful. The production method is developing.</p>	<p>Shrimp prices are generally good and high in comparison to fish prices.</p>
<p>Yellowtail amberjack (<i>Seriola lalandi</i>) 22 °C</p> 	<p>Yellowtail amberjack, or kingfish, is a saltwater species proven to perform well in cages and in RAS.</p>	<p>Market prices good. Sold in specific markets.</p>

Low market prices make the following fish challenging to produce with a profit in recirculation aquaculture, and good marketing and sales efforts are important:

Species	Current status	Market
<p>African catfish (<i>Clarias gariepinus</i>) 28 °C</p> 	<p>A freshwater fish that is very easy to culture. A robust and fast growing fish that performs well in recirculation. Production must be very cost efficient.</p>	<p>Moderate to low prices. Most fish are sold live in local markets. Strong marketing effort required.</p>
<p>Barramundi (<i>Lates calcarifer</i>) 28 °C</p> 	<p>Also called Asian seabass. Lives in both fresh and saltwater. Requires knowledge in larval rearing. Relatively straight forward in grow-out.</p>	<p>Sold primarily in local markets at fair prices. International market expected to grow as global marketing increases.</p>
<p>Carp (<i>Cyprinus carpio</i>) 26 °C</p> 	<p>All carp species will grow very well in recirculation aquaculture systems. Keeping production costs at a minimum is the main challenge.</p>	<p>Carp are regarded as a low price species in most markets, but can fetch higher prices in some markets during seasonal celebrations.</p>
<p>Pangasius (<i>Pangasius bocourti</i>) 28 °C</p> 	<p>This catfish is grown in big earth ponds primarily in Vietnam. Impressive ability to survive and grow at sub-optimal conditions.</p>	<p>Low end product in the global fish market leaves no room for production costs.</p>
<p>Perch (<i>Perca fluviatilis</i>) 17 °C</p> 	<p>A freshwater fish proven to grow well in recirculation although not widely used.</p>	<p>Limited market with fluctuating prices.</p>
<p>Tilapia (<i>Oreochromis niloticus</i>) 28 °C</p> 	<p>One of the predominant aquaculture fish, which is robust and fast growing. Production cost must be kept to a minimum to be competitive.</p>	<p>Sold in the world market at low to moderate prices. Can fetch higher prices locally.</p>
<p>Whitefish (<i>Coregonus lavaretus</i>) 15 °C</p> 	<p>Coregonus is a group of freshwater fish that can be grown in aquaculture and in recirculation systems.</p>	<p>Prices relatively low as there is strong competition from wild caught species.</p>

Very challenging to grow these fish at a commercially viable scale in recirculation aquaculture or in aquaculture in general, because it is either difficult to manage biologically or/and because of tough market conditions:

Species	Current status	Market
<p>Atlantic cod (<i>Gadus morhua</i>) 12 °C</p> 	<p>Fry rearing proven to be successful in recirculation. Grow-out of larger cod needs further development and is as such not well suited for recirculation.</p>	<p>Prices are fluctuating as market is heavily affected by wild stock catches.</p>
<p>Atlantic salmon, Large (<i>Salmo salar</i>) 14 °C</p> 	<p>Larger salmon are traditionally grown in net pens at sea to reach market size of 5 kg or more. Grow-out in huge land based systems using recirculation is developing fast.</p>	<p>Global market dominated by Norwegian marketing. Trend towards certified products.</p>
<p>Bluefin tuna (<i>Thunnus thynnus</i>) 24 °C</p> 	<p>Fattening of wild caught fish is so far the only profitable farming technology. Controlling full cycle at a commercial level in aquaculture is still under development.</p>	<p>Can fetch very high prices in a turbulent worldwide market for tuna.</p>
<p>Cobia (<i>Rachycentron canadum</i>) 28 °C</p> 	<p>Fairly new saltwater aquaculture fish of good meat quality. Grow-out in cage culture. Output seems to be growing, although there are still obstacles in breeding.</p>	<p>Market is not well developed and the fish is unknown in most markets.</p>
<p>Lemon sole (<i>Microstomus kitt</i>) 17 °C</p> 	<p>Not yet fully developed new species in aquaculture due to different obstacles such as genetics, biology, feeding, etc.</p>	<p>High-end product fetching stable and high prices.</p>
<p>Pike perch (<i>Sander lucioperca</i>) 20 °C</p> 	<p>A freshwater fish difficult to farm. Larval stage troublesome, grow-out seems a little easier. Only a few successful recirculation systems for pike perch exist.</p>	<p>Good and fair prices. Demand expected to grow as wild stocks fall and consumption increases.</p>

Chapter 4: Project planning and implementation

The idea of building a recirculation fish farm is often based on very different views on what is important and what is interesting. People tend to focus on things they already know or things they find most exciting, and in the process forget about other aspects of the project.

Five major issues should be addressed before launching a project:

- Sales prices and market for the fish in question
- Site selection including licences from authorities
- System design and production technology
- Work force including a committed manager
- Financing the complete project all the way to a running business.

Sales prices and market

The very first thing is to find out if the fish can be sold at acceptable prices and in sufficient volumes. It is therefore important to carry out a proper market survey before further steps are taken. Fish prices in the shops are very different from the prices you will receive ex farm. Bringing fish from the farm to display at the supermarket is a long process involving procedures for killing, gutting, packing and transport. The costs involved can be significant, and the costs must be included in the overall calculations. The supermarket and middlemen will take their share of the profit, and the loss in weight from gutting the fish will of course make a significant difference in the final weight of the fish you are getting paid for.

Site selection and licensing

Selection of a good site is extremely important. Although recirculation technology claims to be water saving the need for water in fish farming is obvious. Ground water is by far the most preferred water source, because of its purity and relatively cold temperature. Water taken directly from rivers, lakes or the sea is not recommended unless it is treated thoroughly to avoid diseases. If seawater is used, it is most often advisable to construct sand drains or use borehole water.

Figure 4.1 Flow from project idea to end product

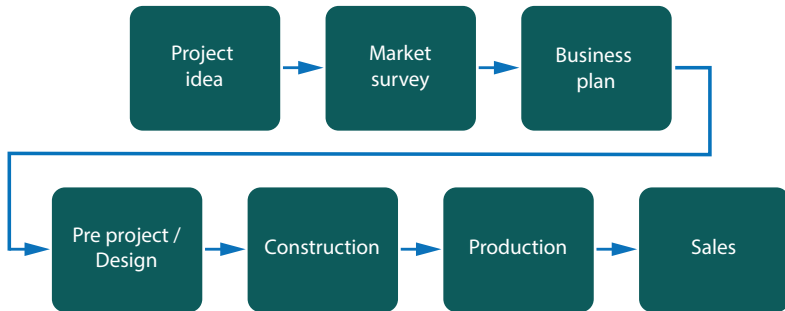

The site selection is also linked to a heavy workload when seeking approval from local, regional, or national authorities to build a fish farm. Much too often it is underestimated how long and how difficult it is to get permission to discharge water from a fish farm. Although the discharge water has been treated thoroughly and all particles removed the nutritious reject water is always of concern to the authorities. It is advisable to have a pre-project made, so that the relevant authorities can be approached in due time for obtaining permits for construction, water usage, discharge, etc.

System design and technology

Many fish farmers tend to design and build systems or solutions themselves, which at first glance is understandable as you want to keep costs down and to have your own ideas incorporated. Historically however many RAS have been under-dimensioned as to the actual requirement of for example oxygen, flow of water, and space to grow a certain volume of fish. Understanding the biological needs of the fish and realizing the scale needed for treatment of waste product in the recirculation process has often been overlooked resulting in incorrect dimensioning and undersizing of systems. Such projects are unfortunate, not only for the owner, but for the reputation of the whole industry. The best approach is to hire a professional system supplier to discuss the ideas for the project and the technology in mind and find out the optimal solution for building the farm in cooperation. The fish farmer should spend his time running and optimizing the fish farm operations instead of getting heavily involved in detailed technical solutions and design work. The collaboration between the fish farmer and the technology supplier is valuable for the success of the project development, but the division of responsibilities must be clear. System suppliers most often work in a very systematic way bringing the project afloat from basic design to construction and finally to start-up of the farm. Some system suppliers even support day-to-day farm management and operational procedures to ensure a proper hand-over and long-term success.

Work force

Finding skilled employees is vital to secure professional management of the farm every day of the year including weekends and nights. It is of utmost importance to find an overall operational farm manager, who is fully committed to the job and wants to succeed as much as the shareholders do. Fish are living creatures and require tight management to grow in a healthy and sound environment. Mistakes or mismanagement will immediately have a huge impact on production and fish welfare. As the aquaculture industry grows and become more professional the need for well-educated employees becomes evident. Training and education is increasingly becoming an important part of modern aquaculture.

Financing

The requirement for financing the complete project is often underestimated. The capital costs are very high when building and starting up a new fish farm, especially when dealing with RAS technology. Investors also seem to forget that growing fish to market size requires patience. The time from starting the construction and getting the first pay-back from fish sold takes from two to four years depending on the size of the project, the location, and the market size of species. To get the cash flow started as early as possible it is recommended to stock more fish into the system in the starting phase and to sell off these excess numbers of fish at a smaller size in the first year until the production logistics have reached the planned daily output of volumes and sizes. Another important issue is to have all costs included when estimating the total need for investment and working capital, and to have a contingency pool available for unexpected malfunctions or needs. In a recirculation system the technology and the biological functioning are inter-dependent. This means that if any of the technology solutions have not been installed or are under-dimensioned or do not work, the recirculation principle will suffer severely. In the end this will affect fish welfare and growth performance resulting in poor fish quality and lower output than planned. In other words, you cannot save your way to success in fish farming.

To get a systematic overview of the whole project, a business plan should be elaborated. It is beyond the scope of this guide to go into details on how to write a business plan or how to conduct a market survey. Detailed information on such subjects must be sought elsewhere. However, a draft business plan and examples of budgets and financial calculations are given in order to guide the reader when setting up a fish farming project.

An introduction for starting up a business and samples of business plans are available online through a simple search or via resources like: www.bplans.com

Figure 4.2 Main items of a business plan (modified from Palo Alto Software Ltd.)

1. Executive summary:

Objective, mission, and keys to success

2. Company summary:

Company ownership, partners

3. Products:

Analysis of products

4. Market analysis summary:

How is the segmentation in the market?
What will be the target market?
What does the market need?
Competitors?

5. Strategy and implementation summary

Competitive edge
Sales strategy
Sales forecast

6. Management summary

Personnel plan and company organisation

7. Financial plan

Important assumptions
Break-even analysis
Projected profit and loss
Cash flow and balance sheet

To sum up on the budgets required in the business plan, these include:

- Investment budget (CAPEX)
(Capital expenditure, total capital costs)
- Operational expenses budget (OPEX)
(Operational expenditure, running the business)
- Cash budget
(Liquidity, business up and running)

It is always advised to consult a professional accountant to make thorough budgets in order to account for all expenses. A well-documented budget is also necessary to convince investors, get a bank loan, and to approach funding institutions.

Production planning

It is also important to plan in detail the biological production of the fish and incorporate the plan carefully into the budgets. The production plan is the basic tool for calculating how many tonnes of fish will be ready for harvest at a given time. The fish farmer will most often stock the farm with several batches of eggs or small fish during the year to secure a constant output of marketable fish over the year. The fish will be graded into different size classes as they grow to end size. The production plan is based on the growth performance of the fish in question and can be described as a growth curve.

Figure 4.3 Expected growth curve for Atlantic salmon reared in RAS at 14 °C

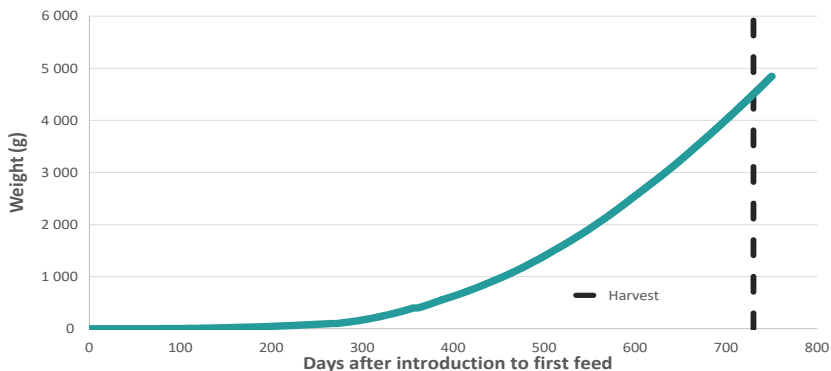

The curve is based on data from feeding tables and adjusted according to experience from RAS salmon farmers.

The production plan should be revised during the production as farmed fish most often perform better – or worse – in practice than as planned. Working out a production plan is basically a matter of calculating the growth of the fish stock, typically from one month to the next. However, practical experience and discussion with other farmers should be taken into consideration when finalizing the plan.

Several software programmes are available for calculating and planning the production. They are all based on computation of interest using the growth rate in percent per day of the fish. The growth rate depends on the species of fish, the size of fish and the water temperature. Different species of fish have different optimal rearing temperatures depending on their natural habitat, and smaller fish have higher growth rates than larger fish.

The feed intake, and the feed conversion rate (FCR) of the feed, is of course an integrated part of these calculations. A way of approaching the production plan is to obtain a feeding table for the fish in question. Such tables are available at the feed manufacturers, and the tables take into consideration the fish species, the size of fish, and the water temperature (see Figure 4.3).

Table 4.1 Example of recommended feeding rate for different sizes of sturgeon given in percentage of fish weight at different water temperatures

Fish size (g)	Pellet size (mm)	13 °C	15 °C	17 °C	19 °C	21 °C	23 °C	25 °C	27 °C	29 °C
50–100	3.0	0.60	0.89	1.04	1.19	1.39	1.44	1.34	1.19	0.99
100–200	3.0	0.50	0.80	0.99	1.09	1.19	1.24	1.14	0.99	0.80
200–800	4.5	0.45	0.70	0.85	0.94	1.04	1.04	0.94	0.85	0.70
800–1 500	4.5	0.35	0.55	0.65	0.75	0.85	0.85	0.75	0.60	0.40
1 500–3 000	6.5	0.20	0.35	0.45	0.55	0.65	0.65	0.55	0.45	0.30
3 000–5 000	9.0	0.15	0.25	0.34	0.39	0.44	0.49	0.44	0.34	0.20
5 000–10 000	9.0	0.12	0.20	0.28	0.31	0.35	0.39	0.35	0.28	0.16

Feeding should be adapted to the production strategy and rearing conditions, likewise the choice of feed type. Feeding according to the recommended level will give the best FCR thus saving feed costs and lowering excretion. Pushing the feeding rate to a higher level will enhance growth at the expense of a higher FCR. Source: BioMar.

Dividing the feeding rate by the FCR will give you the growth rate of the fish. The weight gain from one day to the other can hereafter be calculated using the computation of interest expressed by:

$$K_n = K_0(1+r)^n$$

where “n” is the number of days, “K₀” is the fish weight at day 0, “K_n” is the fish weight at the “n”th day, and “r” is the rate of growth. A fish of 100 g growing at 1.2 percent per day will in 28 days weigh:

$$K_{28 \text{ days}} = K_{100 \text{ g}} (1+0.012)^{28 \text{ days}}$$

$$= 100 (1.012)^{28} = 139.7 \text{ g}$$

Whatever the size or numbers of fish, this equation can be used for calculating the growth of the fish stock, making a precise production plan, and incorporating when to grade and divide the fish into more tanks. Also, it should be remembered to subtract losses in the population when working out the production plan. It is advisable to calculate on a monthly basis, and to use a mortality factor of approximately 1 percent per month depending on experience. A month should not be calculated as 30 full days as there will normally be days in a month where the fish are not fed due to managerial procedures, which is why 28 days is used in the example above.

Costs and investments

The investment costs depend strongly on the construction of the recirculation plant, which again depends on the country and local conditions in the construction area. An example of an investment budget with estimated figures in percent is shown in Table 4.2. Purchase of land is not included.

Table 4.2 Example of investment budget for a full recirculation in-house system with estimated figures in percent. The distribution cost will vary depending on type of system, fish species, and location

Investment budget	Share of capital costs
Civil works: Land development, buildings, concrete works and construction, main piping, electrics, walkways	46 %
RAS: Design and equipment, freight and installation	33 %
Fish tanks incl. in- and outlets	12 %
Feeding and light systems	2 %
Heating, chilling, ventilation	3 %
Fish handling incl. pipes	3 %
Operational equipment	1 %

The costs are also highly dependent on whether the farming system shall breed all fish stages or just the grow-out phase, and if the system is to be installed inside a building or not. Such decisions depend on climate, fish species, aim of the production, etc. There is a clear tendency that the higher the rate of recirculation, the higher the need for installing the system inside a building.

For complete indoor RAS based farms including all facilities such as hatchery, fry and grow-out systems fitted with feeding systems, grading solutions, intake water and waste water treatment etc., the all included total investment cost (CAPEX) will reach between EUR 12 to EUR 20 (or more) per kg produced per year.

Figure 4.4 Example of cost distribution for a single RAS production unit for portion sized trout (2 000 tonnes/year) taking in fingerlings and growing them to 300–500 g

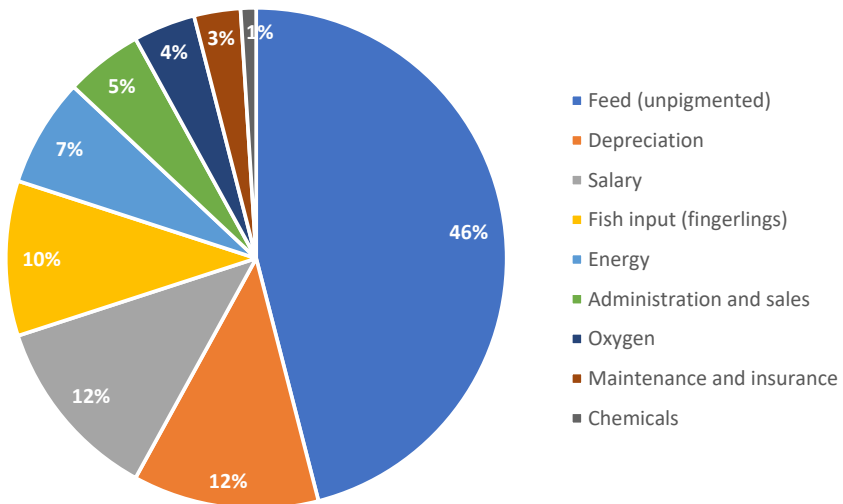

Total production cost per kilogram live fish produced is a little more than EUR 2 per kg.

The larger the harvesting size of the fish farmed, the higher the investment cost, because growing larger fish requires more system and tank space to produce the same tonnage when compared to smaller fish. Thus, systems for producing large fish, such as market size salmon of 4–5 kg will be at the high end of around EUR 20 per kg produced per year for the complete system all included. At the other end of the scale, a complete RAS project for producing portion sized trout will be less expensive, because the production efficiency per m³ tank volume will be far higher due to the high growth rate of the smaller fish.

The lowest investments will be needed in outdoor fish farming modules producing small market sized fish in less advanced recirculation systems used only for the final grow-out of e.g. tilapia, catfish or trout. The investment cost for such simple RAS grow-out modules, without including costs for buildings, water intake treatment etc., designed only to grow fish from the fry stage to a marketable portion size is estimated to be around EUR 6 per kg produced per year when designed for 1 000 tonnes or more.

Economy of scale must be taken into consideration when engaging in modern fish farming. When doing the budgets, one will realise that building a larger farm will reduce investment costs and operational costs per kg fish produced when compared to setting up a smaller farm. In general, RAS projects for market size fish are from around 500 tonnes to 10 000 tonnes output per year. Smaller projects tend to concern more valuable fish like pike perch or turbot, and larger projects concern lower priced fish like tilapia and catfish. Exemption from the rule is though large salmon RAS on land where the projects are huge although the market price is relatively good. However, this has also to do with the fact that these salmon RAS are producing large slow growing fish compared to smaller and faster growing fish like catfish or tilapia.

Regarding purchase of land, the footprint of a recirculation plant also depends on fish species and the intensity of the production. In general, the footprint of a recirculation facility is roughly about 1 000 m² per 100 tonnes fish. The larger the total production the smaller the area needed per 100 tonnes produced, because the tanks are larger and can be built deeper. Thus, a large fish farm of 1 000 tonnes will require only around 7 000 m². More land will often be needed for surrounding works such as water intake, water discharge treatment, fish loading, roads, etc.

From the example in Figure 4.4 it is interesting to note the consumption of energy at 7 percent of the costs. Focus on the electricity consumption is always important although it is not a dominant cost. In fact, the electricity cost of many types of RAS is not much higher than many traditional farms where the use of paddle wheels, return pumps, oxygen cones, and other installations use quite a substantial amount of energy.

As can be seen in Figure 4.4 the cost of feed is by far the dominant cost, which also means that good management is the most important factor. Improving the FCR will have a significant positive impact on the efficiency of the production as fish will put on more weight per kg feed used and the load on mechanical and biological filters of the RAS will be less.

The appendix has a checklist of biological and technical issues that can affect the implementation of a recirculation system. This checklist is most suitable for identifying details and possible obstacles when the project is about to be realised.

Chapter 5: Running a recirculation system

Moving from traditional fish farming to recirculation significantly changes the daily routines and skills necessary for managing the farm. The fish farmer has now become a manager of both fish and water. The task of managing the water and maintaining its quality has become just as important, if not more so, than the job of looking after the fish. The traditional pattern of doing the daily job on a traditional flow-through farm has changed into fine tuning a machine that runs constantly 24 hours a day. Automatic surveillance of the whole system ensures that the farmer has access to information on the farm at all times, and an alarm system will call if there is an emergency.

Figure 5.1 Water quality and flow in filters and fish tanks must be observed frequently



E.g. the aeration pattern of the fixed bed biofilter shown in the foreground must be stable and uniform.

Routines and procedures

The most important routines and working procedures are listed below. Many more details will occur in practice, but the overall pattern should be clear. It is essential to make a list with all the routines to be checked each day, and lists for checking at longer intervals.

Daily or weekly:

- Visually examine the behaviour of the fish
- Visually examine the water quality (transparency/turbidity)
- Check hydrodynamics (flow) in tanks
- Check distribution of feed from feeding machines
- Remove and register dead fish
- Flush outlet from tanks if fitted with stand-pipes
- Wipe off membrane of oxygen probes

- Registration of actual oxygen concentration in tanks
- Check water levels in pump sumps
- Check nozzles spraying on mechanical filters
- Registration of temperature
- Make tests of ammonia, nitrite, nitrate, pH
- Registration of volume of new water used
- Check pressure in oxygen cones
- Check NaOH or lime for pH regulation
- Control that ozone dosing and/or UV-lights are working
- Register electricity (kWh) used
- Read information from colleagues on the message board
- Make sure the alarm system is switched on before leaving the farm.

Weekly or monthly:

- Clean the biofilters according to the manual and your own observations
- Check sumps etc. for dirt settlement (camera can be useful)
- Drain condense water from compressor
- Check water level and alarm function in buffer tank
- Check amount of remaining O₂ in oxygen tank
- Calibration of pH-metre
- Calibration of feeders
- Calibrate O₂ probes in fish tanks and system
- Check alarms – make alarm tests
- Check that emergency oxygen works in all tanks
- Check all pumps and motors for failure or dissonance
- Check generators and make a test-start
- Check that ventilators for trickling filters are running
- Grease the bearings of mechanical filters
- Rinse spraybar nozzles on mechanical filters
- Search for “dead water” in system and take precautions
- Check filter sumps - no sludge must be observed.

6–12 months:

- Clean UV sterilizer, change lamps yearly
- Change oil and oil-filters and air-filter on compressor
- Check if the cooling towers are clean inside
- Check if degasser is dirty and clean if necessary
- Clean biofilter thoroughly if necessary
- Service the oxygen probes
- Change spraybar nozzles in mechanical filters
- Change filter plates in mechanical filters.

Figure 5.2 Oxygen generator. Control and service of special installations must be taken care of. This is often secured by a service agreement with a specialized company



Water quality

Managing the recirculation system requires continuous registration and adjusting to reach a perfect environment for the fish cultured. For each parameter concerned there are certain margins for what is biologically acceptable. Throughout the production cycle each section of the farm should if possible be shut down and started up again for a new batch of fish. Changes in production affect the system as a whole, but especially the biofilter is sensitive to dry outs or other alterations. In Figure 5.3 the effect on the concentration of nitrogen compounds leaving a newly started biofilter can be observed. Fluctuations will occur for many other parameters of which the most important can be seen in Figure 5.4. In some situations, parameters may increase to levels which are unfavourable or even toxic to fish. However, it is impossible to give exact data on these levels as the toxicity depends on different things, such as fish species, temperature and pH. The fish will most often adapt to the environmental conditions of the system and tolerate higher levels of certain parameters, such as carbon dioxide, nitrate and/or nitrite. Most important is to avoid sudden changes in the physical and chemical parameters of the water.

Figure 5.3 Fluctuations in the concentration of different nitrogen compounds when starting up and maturing a biofilter

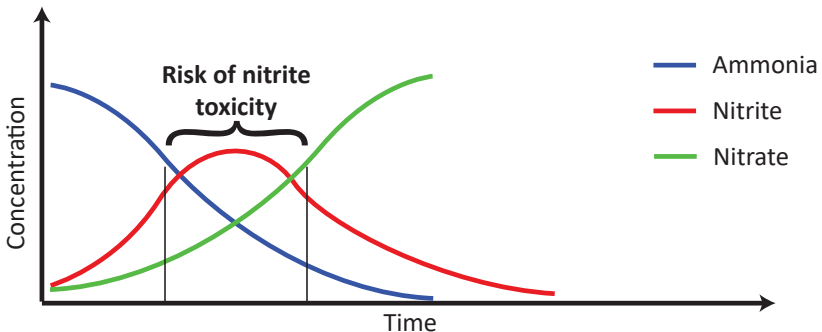

Table 5.1 Preferable and unfavourable levels for different physical and chemical water quality parameters in a freshwater recirculation system

Parameter	Formula	Unit	Normal	Unfavourable level
Temperature		°C	Depending on species	Depending on species
Oxygen	O ₂	%	70–100	< 40 and > 250
Nitrogen	N ₂	% saturation	80–100	> 101
Carbon dioxide	CO ₂	mg/L	10–15	> 20
Ammonium-N	NH ₄ ⁺	mg/L	0–2.5 (pH influence)	> 2.5
Ammonia-N	NH ₃	mg/L	< 0.01 (pH influence)	> 0.025
Nitrite-N	NO ₂ ⁻	mg/L	0–0.5	> 0.5
Nitrate-N	NO ₃ ⁻	mg/L	100–200	>300
pH			6.5–7.5	< 6.2 and > 8.0
Alkalinity		mg /L as CaCO ₃	70–200	< 70
Phosphorus	PO ₄ ³⁻	mg/L	1–20	Unknown
Suspended solids	SS	mg/L	10–25	> 100
COD (Chemical Oxygen Demand)	COD	mg/L	25–100	Unknown
BOD (biological oxygen demand)	BOD	mg/L	5–20	> 20
Turbidity		NTU	1–3	> 4
hydrogen sulphide	H ₂ S	µg	< 5 (pH influence)	> 5
Calcium	Ca ⁺⁺	mg/L	5–50	Unknown

A saltwater environment will change some of the levels stated. The list is a general overview for guidance. Some species need cleaner water than others. Fry and small fish will always require cleaner water than larger fish.

The toxicity of the nitrite peak can be eliminated by adding salt to the system. A salt concentration in the water of just 0.3 o/oo (ppt) is sufficient to inhibit the toxicity of nitrite. Suggested levels for different physical and chemical water quality parameters in a recirculation system are shown in Table 5.1.

Biofilter maintenance

The biofilter must be working at optimally at all times to secure a high and stable water quality in the system. The following is an example of procedures for maintenance of the biofilter.

Figure 5.4 Principle drawing of pre-fabricated biofilter made of polyethylene (PE)



Normally PE biofilters are placed above ground level and fitted with a sludge discharge valve for easy flushing and cleaning. The sludge water is lead to the wastewater treatment system outside the aquaculture recirculation system. The picture on the right reveals the size of a large PE biofilter. Source: AKVA group.

Biofilter maintenance includes:

- Brush the top plate every second week to avoid bacteria and algae developing and eventually blocking the holes in the perforated top plate
- Brush and clean the microbubble diffusers in the process water pipe from last biofilter chamber to microparticle filter every second week
- Regular monitoring and cleaning schedule

Figure 5.5 The flow pattern in the shown multi chamber PE biofilter goes from left to right and upstream in each chamber



Most of the organic material is removed by heterotrophic bacteria in the first chamber. The consequent low organic load in the latter chambers secures a thin nitrifying biofilm for converting ammonia to nitrate. The last chamber is called a microparticle filter and is designed for removal of very fine particles that have not been removed by the mechanical filter. This type of filter can also be created in concrete.

The following parameters should be checked regularly:

- Check the distribution of air bubbles across each of the biofilter chambers. Over time the biofilter will accumulate organic matter, which will impact the distribution of air bubbles and increase the size of the bubbles
- Check the height between the water surface level in the biofilter and the PE cylinder wall top edge to identify flow changes through the biofilter and microparticle filter
- Regularly measure the water quality parameters that have most relevance to the biofilter
- Closely monitor the remaining volume of base or acid used for dosing.

Cleaning and flushing for sludge removal in biofilter

A mix of inorganic material, dislodged biofilms and other organic matter that is difficult to break down by the microorganisms may accumulate below the bio-media in the biofilter. This should be removed by the sludge removal system placed in the chambers.

For sludge removal flush follow the protocol below:

- Bypass the PE biofilter that is to be cleaned
- Open outlet discharge valve for few seconds (approx. 10 sec.)
- If sludge pump is installed: Pump the sludge from PE biofilter and check for a brown coloration in the water
- Continue this procedure for all biofilters and microparticle filters (and turn off the sludge when finished). Ensure there is no siphoning from the biofilter chambers via the sludge pump. If there is a possibility of losing water this way, shut all the outlet discharge valves.

Simple cleaning of biofilter using air

Twice a week it is recommended to apply a simple cleaning protocol. In this procedure the PE biofilters are cleaned by air.

For simple biofilter clean follow the protocol below:

- Do not change the flow to the biofilter
- Open the air cleaning valves on the first PE biofilter
- Check that the cleaning blower is ready for operation. Turn this blower on
- Direct all cleaning air to biofilter #1 for 10–15 minutes. The process water flow through the biofilter will transfer the loosened organic materials to the following chamber
- Direct all cleaning air to the next PE biofilter for 10–15 minutes. Continue the procedure through to the last biofilter. Exclude the microparticle filter
- All the loosened organic material finds its way to the microparticle filter.

Microparticle filter cleaning

The regularity of cleaning the microparticle filter depends on the load on the system. As a guideline it is recommended to clean the microparticle filter every week.

For simple micro-particle filter cleaning follow the protocol below:

- Stop the flow through the PE biofilters
- Reduce the water level to 100 mm below the top plate of the microparticle filter using the sludge discharge valve (use the sludge pump if available)
- Shut the air cleaning valves on all PE biofilter chambers. Open the microparticle filter chamber air cleaning valve
- Check with the engineer that the cleaning blower is ready for operation. Turn this blower on
- Direct all cleaning air to the microparticle filter for 30 minutes. This volume of air raises the water level to near the outlet boxes. The foul water should not be allowed to exit the outlet box
- Following the cleaning discharge the entire microparticle filter volume using the protocol described for the sludge removal flush.

Deep cleaning of biofilter

If the head difference between biofilter and/or microparticle filter chambers increases and the normal head difference cannot be re-established by normal cleaning, then a biofilter deep clean procedure is required. Use regular measurements in each biofilter chamber, between the top of the water level and the PE cylinder top edge to identify flow problems through the biofilter and microparticle filter.

Before completing a deep rinse shut off the aeration in the given chamber for two hours before completing the clean. The given chamber will then act like a microparticle filter for this short period collecting extra waste which is to be discharged during the cleaning process. As a guideline it is recommended that all areas of the biofilters are deep cleaned every month.

For deep biofilter filter cleaning follow the protocol below:

- Stop the flow through the PE biofilters
- Use heavy aeration for 30 minutes in the filter(s) to be cleaned. Then completely empty the given filter(s) using the protocol described for the sludge removal flush.

Sodium hydroxide (NaOH) cleaning

If severe blocking in biofilter system is identified, complete a sodium hydroxide cleaning. Severe blocking may be identified by continuous problems with head difference between the chambers, signs of uneven aeration across the top of the chamber and/or reduced biofilter performance.

For a sodium hydroxide cleaning follow the protocol below:

- Empty the filter section
- Refill with freshwater and a sodium hydroxide solution (NaOH, adjusted to pH 12)
- Leave this to work for an hour with aeration and then empty the filter again using the protocol described for sludge removal flush.

This treatment should only be necessary if the biofilter has not received maintenance regularly. It will take several (20–40) days until the sodium hydroxide cleaned chamber is back at full capacity.

Trouble shooting biofilter problems:

Table 5.2 List of problems with reasons and possible solutions.

Problem	Reason	Solution
Increased turbidity	Too much aeration	Lower aeration
	Reduced flow rate to biofilter	Open valve between degasser and biofilter, increase flow
Increasing TAN level	Too much aeration, reduced nitrification performance due to damage to the biofilm	Lower aeration
Increasing nitrite and TAN levels	Too high organic load	Make sure feeding does not exceed system specs. Check mechanical filter function.
Decreasing nitrate level	Anaerobic activity	Increase aeration, clean biofilter
Hydrogen sulphide (H ₂ S) production (smell of rotten egg when cleaning)	Anaerobic activity	Increase aeration, clean biofilter
Increasing alkalinity	Anaerobic activity	Increase aeration, clean biofilter
Reduced flow to biofilter	Partly closed inlet valves	Open valve between degasser and biofilter, increase flow
	Blocking of biofilter, insufficient cleaning of the biofilter	Clean biofilter according to schedule and production specific demands
Reduced or no aeration	Blower failure	Check blower, intake air filter, fuse, and power

Precautions



Water that is under aeration has a lower density than normal water making swimming impossible!



An operator should only walk on the biofilter top plates whilst wearing a safety harness! Correct footwear must be worn, and care must be taken on the extremely slippery surface!



Follow all instructions with regards to safety procedures for the use of tools, chemicals, machines, and any other!

Oxygen control

Dissolved oxygen (DO) is one of the most important parameters in fish farming, and it is important to understand the relationship between percent saturation and mg/L. When water is saturated with air it has a DO of 100 percent saturation. The correct monitoring of the oxygen levels on the farm is vital for the overall operation of the fish farm.

The oxygen content in milligram oxygen per litre of water depends on the temperature, salinity and barometric pressure. At a barometric pressure of 1013 mbar 100 percent saturation in freshwater equals 12.8 mg/L at 5°C, but only 7.5 mg/L at 30°C. This means that in cold water there is much more oxygen available for the fish to consume than in warm water. Thus, farming fish in warm water requires even more intense oxygen monitoring and control than farming in cold water. For saltwater the saturation is poorer than in freshwater.

Figure 5.6 Concentration in mg/L at 100% saturation of dissolved oxygen (DO) in fresh water and in saltwater

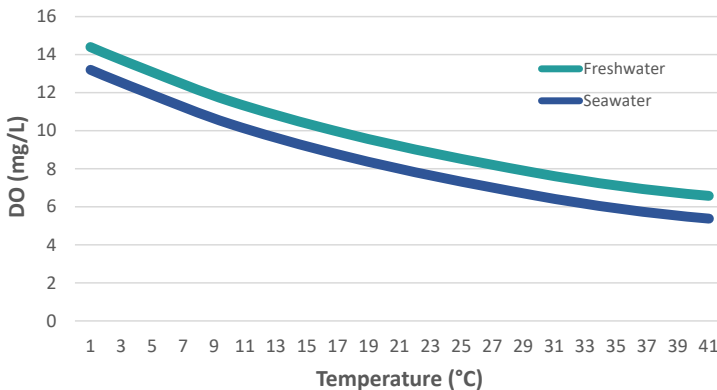

The concentration is higher in cold water than in warm water.

Table 5.3 Dissolved oxygen in fresh water in mg/L at 100 percent oxygen saturation

Dissolved oxygen in fresh water												
mm Hg	700	710	720	730	740	750	760	770	780	790	800	
mbar	933	946	960	973	986	1000	1013	1026	1040	1053	1066	
Temperature												
°C	°F											
0	32	13.4	13.6	13.8	14.0	14.2	14.4	14.6	14.8	15.0	15.2	15.4
5	41	11.8	11.9	12.1	12.3	12.4	12.6	12.8	12.9	13.1	13.3	13.4
10	50	10.4	10.5	10.7	10.8	11.0	11.1	11.3	11.4	11.6	11.7	11.9
15	59	9.3	9.4	9.5	9.7	9.8	9.9	10.1	10.2	10.3	10.5	10.6
20	68	8.4	8.5	8.6	8.7	8.8	9.0	9.1	9.2	9.3	9.4	9.6
25	77	7.6	7.7	7.8	7.9	8.0	8.1	8.2	8.4	8.5	8.6	8.7
30	86	6.9	7.0	7.1	7.2	7.3	7.4	7.5	7.6	7.7	7.8	7.9
35	95	6.4	6.5	6.6	6.7	6.8	6.8	6.9	7.0	7.1	7.2	7.3
40	104	5.9	6.0	6.1	6.2	6.2	6.3	6.4	6.5	6.6	6.7	6.7

The salinity's effect on the oxygen content at the highlighted column can be seen in Table 5.4 below.

Table 5.4 Dissolved oxygen in saltwater in mg/L at 100 percent oxygen saturation

Dissolved oxygen in saltwater (at 760 mm Hg)						
Salinity parts per thousand	0	10	20	30	40	
Temperature						
°C	°F					
0	32	14.6	13.6	12.7	11.9	11.1
5	41	12.8	11.9	11.2	10.5	9.8
10	50	11.3	10.6	9.9	9.3	8.7
15	59	10.1	9.5	8.9	8.4	7.9
20	68	9.1	8.6	8.1	7.6	7.2
25	77	8.2	7.8	7.4	7.0	6.6
30	86	7.5	7.1	6.8	6.4	6.1
35	95	6.9	6.6	6.2	5.9	5.6
40	104	6.4	6.1	5.8	5.5	5.2

There is also a difference of the availability of dissolved oxygen in fresh water versus saltwater. In fresh water the availability of oxygen is higher than in saltwater (see Tables 5.3 and 5.4).

Modern equipment has sensors for temperature and barometric pressure to give correct values at all times. When measuring oxygen in saltwater, simply write in

the level of salinity in the menu of the oxygen metre and the metre will automatically adjust accordingly.

This means that calibration of for example a hand held oxygen metre is quite simple.

Accurate measurements need accurate calibration, which in turn needs stable conditions.

Figure 5.7 Handy Polaris oxygen metre for measuring oxygen content of the water in mg/L and % saturation



Source: Oxyguard International.

Education and training

Management of the fish farm is just as important as having the right technology installed. Without properly educated and trained people the efficiency of the farm will never be satisfactory. Fish farming in general requires a wide range of competencies from broodstock and hatchery management, weaning and nursing of fish larvae, fry, and fingerling production to grow-out of market size fish.

Training and education is available in many forms from practical hands-on courses to academic studies at universities. A combination of theory and practice is the best combination to gain an all-round understanding of how to run a recirculation aquaculture system.

The following is a listing of the areas that should be considered when building up an educational programme:

Basic water chemistry

Understanding the basic chemical and physical water parameters important for the farm operation, such as ammonium, ammonia, nitrite, nitrate, pH, alkalinity, phosphorus, iron, oxygen, carbon dioxide and salinity.

System technology and management in general

Understanding different system designs, primary and secondary water flows. Production planning, feeding regimes, feed conversion rate, specific growth rate relations, registration and calculations of fish size, numbers, and biomass. Knowledge of emergency installations and emergency procedures.

Consumables

Understanding fish feed compositions, feeding calculations and distribution, water consumption levels and sources, electricity and oxygen consumptions, pH adjustments using of sodium hydroxide and lime.

Parameter readings and calibration

Understanding readings from sensors of oxygen, carbon dioxide, pH, temperature, salinity, pressure, etc. Ability to test and calculate levels of ammonia, nitrite, nitrate, TAN, and understanding the nitrogen cycle. Calibration of devices for measuring oxygen, pH, temperature, carbon dioxide, salinity, waterflow, etc. PLC and PC settings for alarms, emergency levels, etc.

Machinery and technical installations

Understanding the mechanics and maintenance required for the system, such as for the mechanical filter, the biofilter system including fixed bed and moving bed, degassers, trickling filters and denitrification filters. Operational knowledge of UV systems, pumps, compressors, temperature control, heating, cooling, ventilation, oxygen injection systems, emergency oxygen systems, oxygen generator and oxygen back-up systems, pH regulation systems, pump frequency converter systems, electrical generator systems, PLC and PC systems, automatic feeding systems.

Operational knowledge

Practical knowledge from working on a fish farm including handling of broodstock, eggs, fish larvae, fry, fingerlings, and grow-out of larger fish for market. Hands-on experience from fish handling, grading, vaccination, counting and weighing, mortality handling, production planning, and other daily work at farm level. Understanding the importance of biosecurity precautions, hygiene, fish welfare, fish diseases and correct treatment.

Management support

When starting a recirculation system there are many things to attend to and it can be difficult to prioritize and focus on the right items. To have the system

up and running at optimal level and at full production is most often extremely challenging.

Supervision or management support of the day-day production conducted by a professional and experienced fish farmer can be a way to overcome the starting phase and to avoid mismanagement. Also, continuous education and training on site of the farm personnel can be a part of the support.

The fish farmer should build a team of skilled personnel to run the fish farm 24 hours a day 7 days a week. The team members will most often work in shifts to account for night watch and work on weekends and holidays.

Personnel in the team should consist of:

- One manager with overall responsibility for the day-to-day practical management on the fish farm
- Assistants referring to the manager with responsibility for practical work on the farm with special emphasis on the husbandry of the fish
- One or more technicians with responsibility for maintenance and repair of technical installations
- Other workers for miscellaneous work will most often have to be hired.

It is important to make sure that the team actually has the time available to undergo training on site to optimize their skills. Quite often training is neglected because the daily work has higher priority and there seems to be no time at all for learning. However, this is not the right way to build a new business. Any chance of increasing knowledge and working in a more efficient and professional way should have the highest priority.

Service and repair

A service and maintenance programme should be made for the recirculation system to ensure that all parts are working at all times. In the beginning of this chapter routines have been listed and care should be taken on how to solve any malfunctions. It is recommended to make service agreements with suppliers of different equipment to have professional service at hand and at regular intervals.

It is also important to secure efficient spare part deliveries together with the service regimes. A complete spare part package for the most important items together with redundancy machinery such as water pumps and blowers should be stored at the farm for immediate use.

Fish feeding

Feeding is one of the most important tasks in any fish farm as feed is by far the highest cost in fish production, thus skillful feeding is of major importance to be successful. In RAS the feeding requires extra attention compared to other fish farming systems. The reason is that spilled feed and/or poor conversion rates will have a direct effect on the actual capacity of the biofilter. Uneaten feed or poorly digested feed will increase the load on the biofilter and the farmer is left with less production capacity. Poor conversion rates or uneaten feed also increases the amount of dirt produced and thereby the risk of unwanted sedimentation in different parts of the system.

Figure 5.8 A sketch of an automatic feeding system

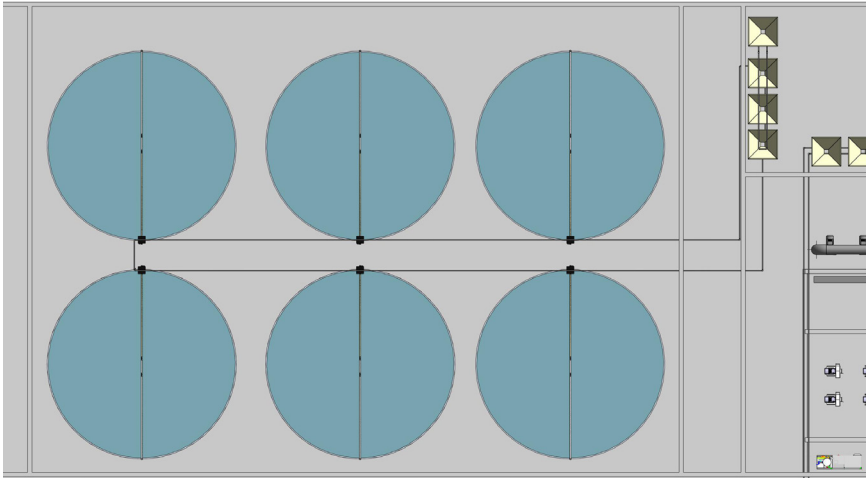

Different sizes of feed pellets are stored in silos (upper right) and distributed in a conveyor pipe system for filling the hoppers at tank side. From the hopper feed at a given size is distributed evenly across the fish tank by an auger. A software programme controls the intervals of the feeding doses and the total amount of feed per day.

Figure 5.9 An example of an automated feeding system

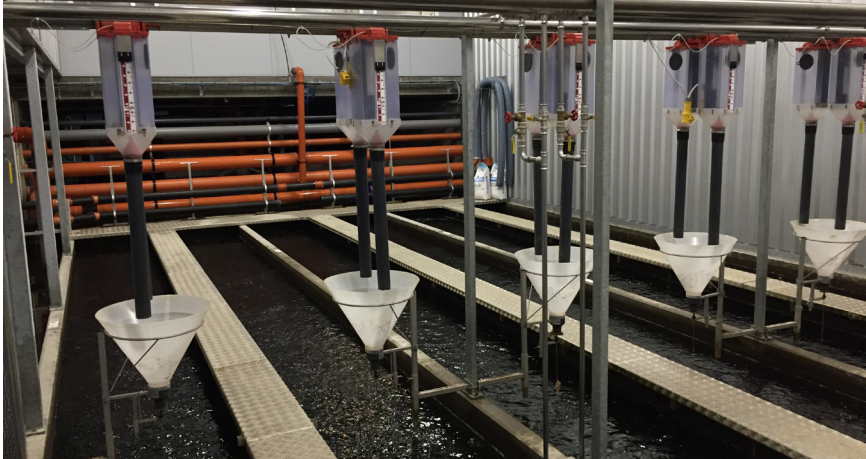

Source: FREA Aquaculture Solutions.

Most feeding in RAS today is done automatically by feeding machines most often consisting of hoppers placed at each tank that are filled daily by hand or by an automatic filling system. A good distribution of feed over the entire water surface improves feeding performance and ensures that all fish have easy access to feed during the day. The traditional pendulum demand feeder activated by fish striking a pendulum hanging from the hopper into the water is a simple and reliable solution, however here the strongest fish may easily be favoured. Fully automatic feeding systems spread the feed by a spinning wheel or pressurised air, and some systems are fitted with an auger across the entire tank to secure the most efficient distribution.

Special feeds for recirculation technology have been developed, both with regard to nutritional composition and with regard to the physical structure of the pellet. Avoiding the formation of dust or breaking the pellets when distributing feed is crucial. Dust is a simple loss of feed and broken pellets are inefficient in use. One should therefore be careful to have a reliable feeding system designed and installed.

Figure 5.10 The vacuum pump below pumps live fish from a fish tank to the grader above



The fish are graded into different size categories before they are counted using infrared light and returned to the tanks by gravity.

Source: IRAS A/S.

Fish handling

Farmed fish are handled and moved in between tanks several times during the production period from the fry stage all the way to the finished product. Being efficient in fish farming is all about utilizing tanks and tank volumes in the best possible way. This means that fish, as they grow, will need to be moved to new and most often larger tanks to give more space for growing. When fish are moved, they are most often graded into different size categories to practically handle the flow of fish until harvest. Grading fish also prevents aggression and the stock also grow better if the fish are uniform in size.

Fish must be counted when they are handled to keep track of how many fish are in each tank and what the biomass is. Fish are counted automatically using a counter fitted to the grader or placed at the end of the fish transportation pipe before fish enters the tank. Most fish counters work by infra-red light that detects when fish passes. To calculate the biomass of fish in a tank the number of fish counted is multiplied by the mean weight of the fish. This means that a sample of fish must be taken out to calculate the mean weight of the fish. Smaller fish can be counted into a bucket with water and weighed to calculate the mean weight whereas samples of larger fish require other methods, for example counting a sample of fish in a larger catch net placed in the water that is lifted and weighed.

Mortality handling

Farming fish will always result in mortalities. Even in a perfect RAS environment there will always be some dead fish, also called morts, to be picked up from the fish tanks. To keep the facility clean and hygienic, picking up mortalities every day is key. Dead fish lying around will create an unwanted environment of bacteria and fungus that will increase the risk of healthy fish getting infected. In a well operated RAS mortalities will not be a problem, but if a disease strikes or an accident happens the amounts of dead fish can be significant, and the methods and ways of disposal have to be solved beforehand.

Fry rearing is associated with higher numbers of dead fish than growing large fish. When the fish eggs hatch and the fry start swimming and feeding, they are very susceptible to infections and it is often necessary to clean out and remove mortalities twice a day to keep the hygiene standards high. Dead fry are removed using a hand net or by suction using a handheld siphon or through a permanently installed mortality outlet mounted in the tank.

Figure 5.11 Mortality removal through outlet pipe from tank bottom center to outlet box at the side of the tank



The box is fitted with a screen holding back the morts for disposal. The outlet pipe shown can be adjusted towards the bottom to reach best possible suction head.

Removing dead fish from fish tanks becomes increasingly difficult as the fish grow and likewise the size of tanks which can reach diameters of 20 m or more with depth of 6 m or more. Instead of picking up mortalities using a net, a system has been invented for taking out dead fish through a hole or a pipe in the centre of the tank. Some systems use air to momentarily create a faster current and others use simple gravitation to suck up the fish.

When fish grow bigger, they generally become more resistant to infections, but dead fish will still be a part of running a fish farm. As the fish grow dead fish becomes a higher cost because of the bigger sizes. Losing a fish of 2 kg is of course a higher cost than losing a fry of 2 g. Whatever the cost, high or low, a basic rule in fish farming is: Do not lose your fish. You have invested everything in those live fish swimming around in your farm: Feed, oxygen, labour, electricity, interest rate etc. So, preventing fish from dying is key in fish farm management.

In previous times mortalities would be incinerated or disposed of in landfills or the nutritious waste could be used in fishmeal production or as an ingredient in pet food. However, regulations and other concerns have made it necessary to look in other directions, such as anaerobic digestion, also known as biogas production. Depending on the location of the fish farm morts will simply be picked up at farm level or alternatively the morts will need to be chopped up and processed before they are collected.

Chapter 6: Wastewater treatment

Farming fish in a recirculation system where the water is constantly reused does not make the waste from the fish production disappear. Dirt and excretions from the fish still have to end somewhere. For the purpose of cleaning the wastewater a wastewater treatment (WWT) must be established.

Figure 6.1 Excretion of nitrogen (N) and phosphorus (P) from farmed fish. Note the large amount of N excreted as dissolved matter

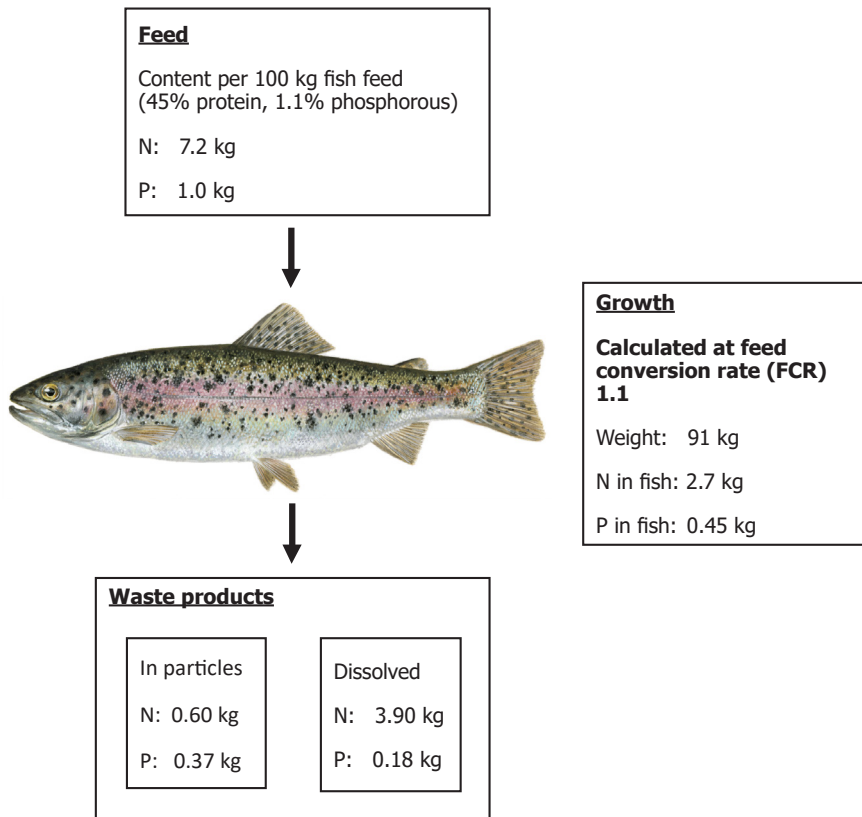

Source: Biomar and the Environmental Protection Agency, Denmark.

Inside the RAS faeces from the fish tanks should flow immediately to the mechanical filter without being crushed on the way. The more intact and solid the faeces are, the higher the level of removed solids and other compounds, and the less discharge from the RAS. Table 6.1 shows the estimated removal of nitrogen, phosphorus and suspended solids (organic matter) in a mechanical filter of 50 micron.

Table 6.1 Removal of nitrogen (N), phosphorus (P) and suspended solids (SS) from mechanical filters with different mesh sizes and tank shapes

Parameter	Raceway	Raceway	Raceway	Self cleaning tank	Self cleaning tank	Self cleaning tank
	40 µ	60 µ	90 µ	40 µ	60 µ	90 µ
	Efficiency, %	Efficiency, %	Efficiency, %	Efficiency, %	Efficiency, %	Efficiency, %
Total P	50–75	40–70	35–65	65–84	50–80	45–75
Total N	20–25	15–25	10–20	25–32	20–27	15–22
Total SS	50–80	45–75	35–70	60–91	55–85	50–80

Source: Fisheries Research Station of Baden-Württemberg, Germany.

The higher the rate of recirculation the less new water will be used, and the less discharge water will need to be treated. In some cases, no water (at all) will return to the surrounding environment. However, this kind of “zero discharge” fish farming is costly to build and the running costs for the waste treatment can be significant. Also, daily operation of the waste treatment will require significant attention to make it work efficiently. Authorities and the fish farmer must agree on a discharge permission that allows protecting the environment whilst having an economically viable fish farming business.

The biological processes within the RAS will reduce the amount of organic compounds to some degree, because of bacterial activity and biological degradation within the system. However, a significant load of organic sludge from the RAS will still have to be dealt with.

Figure 6.2 A sketch of flows to and from a recirculation aquaculture system

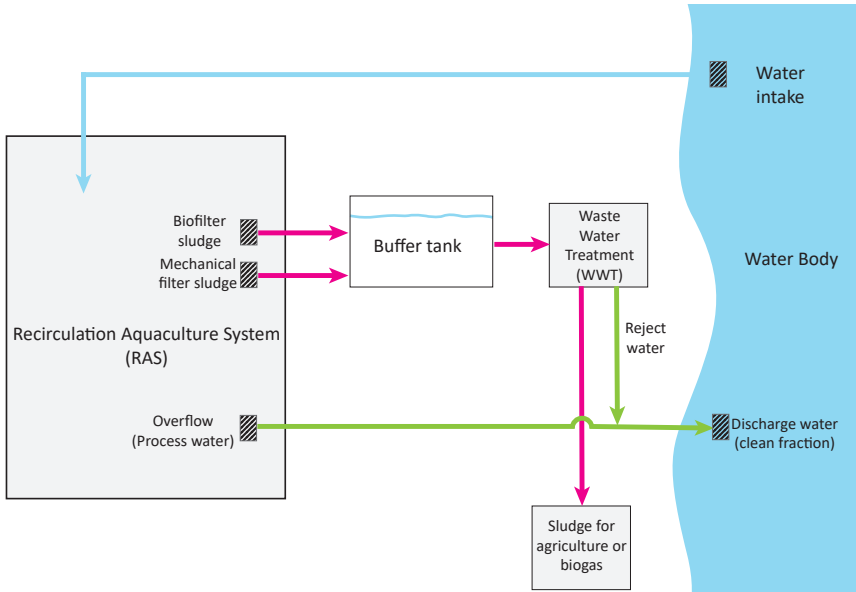

Most RAS will have an overflow of process water for balancing the water going in and out of the system. This water is the same water as the fish are swimming in, and a limited pollutant unless the discharged amount of water from the overflow is excessive and the yearly discharge through this point escalates. The more intensive the rate of recirculation, the less water will be discharged through the overflow. If required by the authorities the overflow water can be directed to the WWT before discharge.

The wastewater leaving the recirculation process typically comes from the mechanical filter where faeces and other organic matters are “cleaned off” into the sludge outlet of the filter. Cleaning and flushing biofilters also adds to the total wastewater volume from the recirculation cycle.

Treating the wastewater that leaves, the RAS can be accomplished in different ways. Quite often a buffer tank is installed prior to the WWT, also called a sludge treatment system where the sludge is separated from the discharge water. The sludge will go to an accumulation facility for sedimentation or further mechanical dewatering before it is spread on land, typically as fertilizer and soil improvement on agricultural farms, or it can be used in biogas production for generating heat or electricity. Mechanical dewatering also makes the sludge easier to handle and minimises the volume whereby disposal costs or regulatory fees can be reduced.

Figure 6.3 The pathways of sludge and water inside and outside a recirculation system

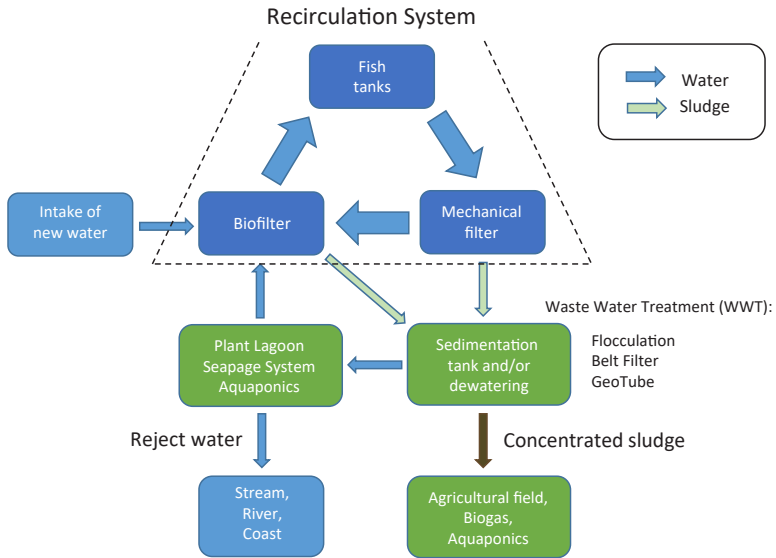

The higher the rate of recirculation, the lower the amount of water let out from the system (dotted line), and the lower the amount of wastewater to be treated. Source: Hydrotech.

Figure 6.4 Hydrotech belt filter used as secondary water treatment for dewatering the sludge



The cleaned wastewater from the sludge treatment will usually have a high concentration of nitrogen, whereas the phosphorus can be removed almost completely in the sludge treatment process. This discharge water is called reject water, and is most often discharged to the surroundings, river, sea, etc. together

Figure 6.5 Reject water from a recirculation trout farm (in the background) runs into a plant lagoon for further cleaning before it is discharged to the river



The lagoon has been established by using the old ponds of the former flow-through farm. Source: Lisbeth Plesner, Danish Aquaculture.

with the overflow water from the RAS. The content of nutrients in the reject water and in the overflow, water can be removed by directing it to a plant lagoon, root zone, or seepage system, where remaining phosphorus and nitrogenous compounds can be further reduced.

As an alternative, the reject water, and to some extent also the sludge, can be used as fertilizer in aquaponics systems. Aquaponics are systems where the waste from the fish is used for growing vegetables, plants or herbs, and are typically inside greenhouses. In other aquaponic systems the fish farm and the

*Figure 6.6 The EcoFutura project explored the possibility of cultivating tomatoes with the growing of Nile tilapia (*Oreochromis niloticus*)*



Source: Priva (Netherlands).

greenhouse are separated units, a combination of horticulture and aquaculture where the flow of nutrients to the greenhouse can be adjusted.

It should be noted that fish excrete waste in a different way than other animals such as pigs or cows. Nitrogen is mainly excreted as urine via the gills, while a smaller part is excreted with faeces from the anus. Phosphorus is excreted with the faeces only. The main fraction of the nitrogen is therefore dissolved completely in the water and cannot be removed in the mechanical filter. The removal of faeces in the mechanical filter will catch a smaller part of the nitrogen fixed in the faeces, and to a larger extent the phosphorus. The remaining dissolved nitrogen in the water will be converted in the biofilter mainly to nitrate. In this form nitrogen is readily taken up by plants and can be used as fertilizer or be removed in plant lagoons or root zone systems.

The removal of nitrate is a significant challenge in wastewater treatment and has become increasingly important as the regulatory framework for discharge water is becoming tighter. This has created a growing interest for efficient nitrate removal and the development of technologies towards a zero-discharge fish farming concept.

The removal of nitrate can be accomplished within the RAS circuit as well as outside in the WWT process. The methods can be combined to reach a more efficient process overall. Both removal processes are based on anaerobic denitrification technology using a carbon source such as methanol. However, the denitrification inside the RAS is focused primarily on reducing the usage

Figure 6.7 Woodchip bioreactor technology used for removal of nitrate in discharge water from an outdoor recirculation aquaculture system for trout



The filter shown holds 6 000 m³ woodchip for cleaning 100 L/sec reject water. The woodchip will act as a carbon source for the denitrifying bacteria transforming nitrate into free nitrogen in an anaerobic environment.

Source: Mathis von Ahnen, DTU Aqua.

of new water whereas the denitrification in the WWT is focused on cleaning off nitrate before discharge. The result of the combination is that the water volume discharged from the RAS is less and thereby easier handled in the WWT. In addition, the denitrification within the RAS adds to the overall removal rate of nitrate.

Denitrification in the RAS is often referred to as zero-water usage although the usage of new water is not zero. The process does however reduce the need for new water by a factor of 10 compared to normal intensive RAS technology. In practical terms this means a reduction from around 300 L of per kg feed used to around 30–40 L.

In the traditional RAS the new water is used for diluting the nitrate level in the process water to a level that enables the fish to thrive and grow. Reducing the nitrate level without dilution requires a denitrification loop where nitrate is converted to free nitrogen gas (N_2) and released into the air. Unfortunately, the reduced water consumption increases the risk of compounds like phosphorus and dissolved metals accumulating in the system. Therefore, a phosphorus removal step using chemical precipitation for removing ionic constituents should be part of the loop (see Figure 6.8)

Figure 6.8 Denitrification loop in a RAS taking the sludge water from the mechanical filter through a settling system before it enters a denitrification chamber

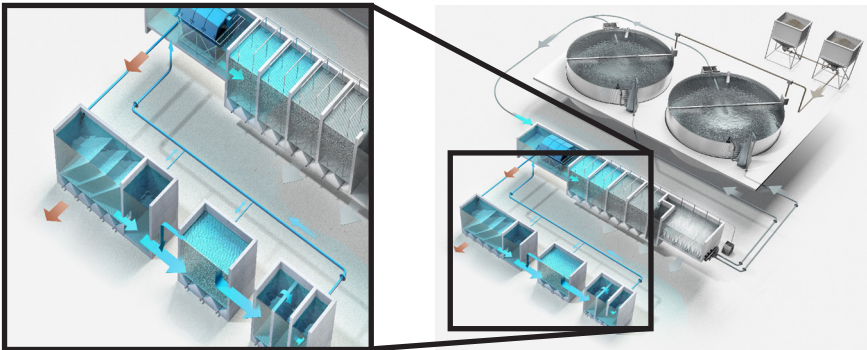

The process should be followed by a precipitation step before being reused in the RAS to prevent phosphorus and dissolved metals from building up. The technology significantly reduces the consumption of water.

Combining intensive fish farming, whether recirculation or traditional, with extensive aquaculture systems, such as for example traditional carp culture, can be an easy way to handle biological waste. The nutrients from the intensive system are used as fertilizer in the extensive ponds when the excess water from the intensive farm flows to the carp pond area. Water from the extensive pond area can be reused as process water in the intensive farm. Growth of algae and water plants in the extensive ponds will be eaten by the herbivorous carp, which

Table 6.2 Comparison of discharge of nitrogen at different recirculation intensities

Trout production, 500 tonnes				
Type of farm and type of treatment	Consumption of new water per kg fish produced per year	Consumption of new water per cubic metre per hour	Consumption of new water per day of total system water volume	Nitrogen discharge, kg per year
Flow-through with settlement pond	30 m ³	1 700 m ³ /h	1 000 %	20 tonnes N
RAS with sludge treatment and plant lagoon	3 m ³	170 m ³ /h	100 %	10 tonnes N
RAS intensive with sludge treatment and WWT denitrification	0.3 m ³	17 m ³ /h	10 %	5 tonnes N
RAS zero discharge with N and P removal and WWT denitrification	0.03 m ³	1.7 m ³ /h	1 %	0 tonnes N

The calculations are based on a theoretical example of a 500 tonnes/year system with a total water volume of 4 000 m³, where 3 000 m³ is fish tank volume. It is not the degree of recirculation in itself that reduces the discharge of nitrogen, but the application of water treatment technology. The lower the consumption of water in the RAS the less water to be treated in the WWT.

Figure 6.9 Combined intensive-extensive fish farming systems in Hungary



The number of opportunities seems unlimited.

Source: Laszlo Varadi, Research Institute for Fisheries, Aquaculture and Irrigation (HAKI), Szarvas, Hungary.

in the end are harvested and used for consumption. Efficient rearing conditions are obtained in the intensive system and the environmental impact has been accounted for in combination with the extensive pond area.

For the innovative entrepreneur there are several opportunities in this kind of recycled aquaculture. The example of combining different farming systems can be developed further into recreational businesses, where sport fishing for carp or put and take fishing for trout can be part of a larger tourist attraction including hotels, fish restaurants and other facilities.

Chapter 7: Disease

There are many examples of RAS operating without any disease problems at all as it is possible to isolate a recirculation fish farm completely from unwanted fish pathogens. Most important, is to make sure that eggs or fish stocked in the facility are absolutely disease free – preferably from a certified disease-free strain. Make sure that the water used is disease free or sterilised before going into the system; it is far better to use water from a borehole, a well, or a similar source than to use water coming directly from the sea, a river or lake. Also, make sure that no one entering the farm brings in any diseases, whether they are visitors or staff. Especially, people working with fish at other places (if entering the facility shortly thereafter) should be carefully disinfected/decontaminated to prevent the potential spread of diseases to the facility.

Whenever possible, a thorough disinfection of the system should be carried out. This includes any new facility preparing for the very first start-up as well as any existing system that has been emptied of fish and is ready for a new production cycle. It should be remembered that a disease in one tank of a recirculation system will most certainly spread to all the other tanks in the system, this spread is even possible despite the use of UV and ozone at the facility, which is why preventive measures are so important.

Figure 7.1 Foot bath with disinfectant solution for preventing the spread of disease



Source: Virkon Aquatic / Syndel.

In recirculation systems using eggs from wild fish, for example for the purpose of re-stocking, getting eggs from certified disease-free strains is not possible. In such cases, there will always be a risk of introducing diseases living inside the egg, such as IPN (Infectious Pancreas Necrosis), BKD (Bacterial Kidney Disease) and possibly herpes virus, which cannot be eliminated by disinfecting the eggs. An example of a prevention scheme is shown in Table 7.1.

A good way to prevent contamination with pathogens within the system is to physically separate the different stages in the production. The hatchery should therefore work as an isolated closed system, as should the fry unit and the grow-out unit. If any broodstock is kept, this should also be isolated in a unit of its own. In this way, stamping out a disease becomes easier to carry out in practice.

Some farms are constructed after the “all in all out” principle, meaning that each unit is emptied completely and disinfected before new eggs or fish are stocked. For eggs and smaller fish, which are grown over a shorter period of time before they are moved on, this is certainly good management, and should always be

Table 7.1 An example of a prevention scheme

What to remember	How is it done?
Clean source of new water	Preferably use ground water. Disinfect using UV. In some cases, use sand filter and ozone.
Disinfection of system	Fill system with water and bring pH up to 11–12 using sodium hydroxide (NaOH). Approximately 1 kg per m ³ water volume depending on buffer capacity. Neutralize before discharge using hydrochloric acid (HCl).
Disinfection of equipment and surfaces	Dip or spray with a disinfectant e.g. Virkon S – according to instructions. Note that salt may inhibit the effect.
Disinfection of eggs	Leave egg batch in solution made of 3 dl 1 % iodine per 50 litres of water for 10 minutes. Change solution for every 50 kg eggs disinfected.
Staff	Change clothing and foot wear when entering facility. Wash or disinfect hands.
Visitors	Change of footwear or use footbath for dipping shoes (disinfectant). Wash or disinfect hands. “Do not touch” policy for visitors inside the facility. People from other fish farms, including the vet, should have a special procedure.

Figure 7.2 Dissection of rainbow trout suffering from inflated swim bladder. A symptom probably due to super saturation of gases in the water



carried out in practice. For larger fish this is also good practice, however this kind of management easily becomes inefficient. Taking all the fish out of a grow-out unit before stocking a new batch is logistically difficult when dealing with large volumes of fish. It easily becomes uneconomical, because of inefficient utilization of the capacity of the system.

Treating fish diseases in a recirculation system is different from treating them on a traditional fish farm. On a traditional fish farm, the water is used only once before leaving the farm. In a recirculation system, the use of biofilters and the constant recycling of water calls for a different approach. Pouring in medication will affect the whole system, not only the fish but also the biofilter. Great care must be taken when treatment is carried out as it is very difficult to give exact prescriptions on the dose needed to cure a disease in a recirculation system, given that the effect of the medication depends on many different parameters such as hardness of water, content of organic matter, water temperature and flow rates. A great deal of practical experience is therefore the only way forward. Concentrations must be increased carefully from each treatment to the next to avoid killing the fish and/or the biofilter. Always remember the term “better safe than sorry”. In any case of a disease outbreak, a local veterinarian or fish pathologist must prescribe the medication and explain how to use it. Also, the safety instructions should be read carefully as some drugs may cause severe injuries to people if used improperly.

Treatment against ectoparasites, which are parasites sitting on the outside of the fish on the skin and in the gills, can be carried out by adding chemicals to the water. Any fungal infections will have to be treated in the same way as infestations with ectoparasites. In freshwater systems the use of ordinary salt (NaCl) is an efficient way of killing most parasites including bacterial gill disease. If a cure with salt does not work, the use of formalin (HCHO) or hydrogen peroxide (H₂O₂) will usually be sufficient to cure any remaining parasitic infections. Bathing fish in a solution of praziquantel and flubendazol has also proven to be very efficient against ectoparasites.

Mechanical filtration is also quite efficient against the spread of ectoparasites. Using a filter cloth of 70 micron will remove certain stages of Gyrodactylus, and a 40 micron filter cloth can remove the eggs of most kinds of parasites.

The safest way of carrying out a treatment is to dip the fish in a bath with a solution of the chemical. However, in practice this is not a feasible method as the volume of fish that needs to be handled is often too large. Instead, fish are kept in the tank as the inlet water is switched off, and oxygenation or aeration of the tank is carried out using diffusers. A solution of the chemical is added to the tank and the fish are allowed to swim in the mixture for a given period of time. Later, the inlet water is opened, and the mixture slowly diluted as the water in the tank is exchanged. The water running out from the tank will be diluted by the rest of the recirculation system so that the concentration going to the biofilter will be significantly lower than in the tank treated. In this way, a relatively high concentration of the chemical can be obtained in an individual tank with the purpose of killing the parasite, yet the possible negative effect of the chemical on the biofilter is contained. Both fish and biofilters can adapt to treatment with salt, formalin and hydrogen peroxide by slowly increasing the concentrations from one treatment to the next. When a tank full of

Figure 7.3 Eggs from rainbow trout



It is advisable to disinfect fish eggs before bringing them into the recirculation system to prevent disease. Source: Torben Nielsen, AquaSearch Ova.

fish has been treated, this water can also be pumped out of the system to a separate compartment for degradation instead of being recirculated in the system.

Using the dipping technique for eggs is an easy way of treating millions of individuals in a short time, for example when disinfecting trout eggs in iodine (Table 7.1). This method can also be used for treating eggs that have been infected with fungus (*Saprolegnia*) simply by dipping the eggs into a solution of salt (7‰) for 20 minutes.

In hatcheries, where fish fry are removed as soon as they are ready to feed, the efficiency of the biofilter is less important as the level of ammonia excreted from eggs and fry is very little. Treatment is therefore easier to carry out, because one must only focus on the survival of eggs and fish. Also, it is worth noting that the total volume of water in a hatchery is relatively small, and a complete water exchange with new water can be carried out rapidly. Therefore, in a hatchery, the whole system can be safely treated in one go.

Treatment of a complete system in larger recirculation facilities is a more sensitive operation. The basic rule is to keep concentrations during the treatment low, and to carry out the treatment over a longer period of time. This requires care and experience. The concentration should be slowly increased from each treatment to the next, leaving several days in between where treatment is interrupted to carefully monitor the effects on fish mortality, behaviour, and water quality. Typically, both the fish and the biofilter will adapt, so the concentration can be increased with no adverse effects and the probability of killing the parasite is enhanced. Salt is excellent for longer treatment periods, but formalin too has been successfully used

Figure 7.4 Salt can be used prophylactically to prevent certain diseases in a RAS or it can be used for treatment when an infection has occurred



Salt can also be used to prevent a sudden toxic effect from nitrite if the biofilter is not fully matured (see Chapter 5). Many RAS use automatic dosing of salt into the main flow to adjust the salinity of the system.

for intervals of 4–6 hours. The biofilter simply adapts to the formalin and digests the substance like any other carbon coming from the organic compounds in the system.

As pointed out previously, it is not possible to give exact concentrations and recommendations on the use of chemicals in a recirculation system. Fish species, size of fish, water temperature, hardness of water, the amount of organic substances, exchange rate of water, adaptation, salinity, etc. must all be taken into consideration. The guidelines below are therefore very approximate.

Salt (NaCl): Salt is relatively safe to use and can be used in fresh water for treating Ich (*Ichthyophthirius multifiliis* – white spot disease) and the common fungus Saprolegnia. Ich in the pelagic phase can be killed at 10 ‰ and new results suggest killing of the bottom living stages at 15 ‰. Fish contains around 8 ‰ salt in their body fluids, and most freshwater fish will tolerate salinities in the water around this level for several weeks. In hatcheries a concentration of 3–5 ‰ will prevent infections with fungus. Note that an increase in the salt concentration of the RAS may push the gas saturation to an unfavourable level, e.g. a tendency in the system of super saturation of nitrogen may suddenly become a problem.

Formalin (HCHO): Low concentrations of formalin (15 mg/L) for long periods of time (4–6 hours) have shown good results in the treatment of *Ichthyobodo necator* (Costia), *Trichodina* sp., *Gyrodactylus* sp., sessile ciliates, and Ich. Formalin is degraded relatively fast in the biofilter at about 8 mg/h/m² biofilter area at 15°C. However, formalin can reduce the bacterial nitrogen conversion rates in the biofilter.

Hydrogen peroxide (H₂O₂): Not widely used, but experiments have shown promising results as a substitute for formalin at concentrations between 8–15 mg/L for 4–6 hours. The biofilter performance can be inhibited during the treatment and for at least 24 hours after treatment, but the efficiency will return to normal within a few days.

Use of other chemicals such as copper sulphate or chloramine-T is not recommended. These are very effective for the treatment of, for example, bacterial gill disease. However, the biofilter will most probably suffer. Thus, the whole recirculation process and the production may easily be affected.

For bacterial infections, such as furunculosis, vibriosis or BKD, the use of antibiotics is the only way to cure the fish. In some cases, fish can become infected with parasites living inside the fish, the way to remove these is also with antibiotics.

Antibiotics are mixed into the fish feed and fed to the fish several times a day over, for example, 7 or 10 days. The concentration of antibiotics must be sufficient to kill the bacteria, and the prescribed concentration of medication and the length of the treatment must be carefully followed, even if the fish stop dying during

the treatment. If treatment is stopped before the prescribed treatment period, there is a high risk that the infection will start all over again.

Treatment with antibiotics in a recirculation system will have a small effect on the bacteria in the biofilter. However, the concentration of antibiotics in the water, compared to that inside the fish being treated with medicated feed, is relatively low, and the effect on bacteria in the biofilter will be much lower. In any case, one should carefully monitor the water quality parameters for any changes because they may indicate an effect on the biofilter. Adjustment of the feeding rate, use of more new water or changing the flow of water in the system may be necessary.

Several antibiotics can be used, such as sulfadiazine, trimethoprim, or oxolinic acid, as prescribed by the local veterinarian.

Treatment against IPN, VHS (Viral Hemorrhagic Septicemia) or any other virus is not possible. However, viruses have a temperature optimum, and it is possible to mitigate the effect of less pathogenic viruses like IPN by increasing the water temperature. For highly pathogenic viruses like VHS the loss of fish can be reduced by lowering the feeding rate. However, running a fish farm that is infected with virus is not the way forward, and the only way to get rid of viruses is to empty the whole fish farm, disinfect the system thoroughly, and start all over again.

Figure 7.5 Vaccination of juveniles is commonly used when fish leaves the RAS to prevent diseases when fish are on-grown in net pens at sea or flow-through systems



Vaccination by manual injection as shown here, can also be done automatically using a vaccination machine.

Chapter 8: Case stories

Pike perch pioneering

The company AquaPri is producing pike perch in a top modern RAS producing 400–500 tonnes of high-quality product per annum, targeting the European market. This freshwater fish is renowned for its pure white meat and mild taste. Pike perch has traditionally been on the menu in many fish restaurants and has now entered sushi restaurants because of its very special and delicate taste. However, growing pike perch is only for the few companies with the skills to manage sensitive larval stages and weaning of juvenile fish to start the on-growing process. Not many have dared to invest in this kind of business, but the Danish family-owned company Aquapri with its fish farming knowledge acquired through generations has demonstrated that pike perch farming in RAS is possible.

Figure 8.1 The RAS for pike perch (or zander/sander) built by AquaPri in 2016 produces 600 tonnes per year



Source: AquaPri A/S.

Yellowtail kingfish

Yellowtail kingfish (*Seriola lalandi*) also known as Ricciola / Hiramasa / greater amberjack is a premium saltwater fish species that was introduced into RAS around 20 years ago.

At that time yellowtail kingfish was already known as an aquaculture species farmed in net pens at sea, and it soon turned out that it was well suited to RAS showing good productivity. However, commercial production developed only slowly.

However, this changed when The Kingfish Company started production at its Kingfish Zeeland facility in the Netherlands. The company is now a leader in large-scale sustainable RAS farming with current annual production capacity at 1 500 tonnes of high-quality yellowtail kingfish and a 2021 harvest and sales volume of over 900 tonnes. Expansion is underway, and capacity at the Dutch facility will reach 3 500 tonnes by the end of 2022. In the United States of America, the planning process for the company's 8 500 tonnes capacity facility is progressing as planned.

Figure 8.2 The Kingfish Zeeland operations are certified and approved as sustainable and environmentally friendly with food safety and quality assurance by Aquaculture Stewardship Council (ASC), Best Aquaculture Practices (BAP), and; British Retail Consortium (BRC)



The Kingfish Zeeland operation was the winner of the 2019 Seafood Excellence Award, and it is recommended as green choice by the Good Fish Foundation. Source: Kingfish Zeeland.

Salmon smolt production in Norway

The salmon farming industry is constantly improving efficiency by speeding up production time and minimizing risks, such as by growing salmon smolt to larger sizes than normal before release to net pens at sea. This leads to shorter time at sea and less risk of infections in the open.

The company Tytlandsvik AQUA from Hjelmeland in Norway has invested significantly in RAS for the production of extra-large smolt. In smolt farming the fish have traditionally been around 100 g before transfer to net pens at sea, but now larger smolt of 200–400 g (post smolt) have become increasingly popular. Tytlandsvik AQUA has taken this a step further and is growing large smolt of 800–1 000 g to benefit even more from the high growth rates in the RAS environment.

Figure 8.3 Overview of the first two RAS built at Tytlandsvik in Norway for production of large smolt of 800–1 000 g before fish are released to net pens at sea for final grow-out to 5–6 kg



Source: Tytlandsvik AQUA.

In addition, the company improves its overall fish logistics by better utilizing the production capacity of its cage sites. Mortality rates have been extremely low at around 0,5 percent from the time it takes to grow fish from 100 g to 800–1 000 g. Currently the company is operating three such RAS each with a capacity of around 6 500 kg feed per day giving an daily biomass increase of 8 000 kg at an FCR at around 0,8.

The production volume of each RAS is 8 000 m³ divided between four tanks each of 2 000 m³. A fourth module will soon be added giving a total capacity of 26 000 tonnes of feed and 32 000 m³ production volume at the site. The output of large smolt will then be approximately 8 000 tonnes per year.

The energy consumption is currently around 4–5 kWh per kg fish produced and is expected to drop to 3 kWh when full capacity at the farm has been reached.

Shrimp farming in RAS

For decades shrimps have been grown outdoor in large water systems or ponds, often with good success due to the low-cost technology and the good harvesting yields. Unfortunately, shrimp farming is also known as an unstable industry with many risks such as flooding, pollution, disease outbreaks etc. Production methods have been criticised and a growing awareness among consumers has forced shrimp producers to rethink the way things are done. Growing shrimp in indoor facilities using RAS technology has become an exciting new part of the shrimp farming era. Shrimp produced in RAS are free of diseases and grow extremely well under clean optimal conditions giving an excellent product for the high end market. The demand for such sustainably produced shrimps is growing and prices are expected to remain strong.

Figure 8.4 SwissShrimp AG have successfully installed and operated this indoor shrimp farm since 2018



The shrimps are grown to sizes between 10 g and 50 g and sold at EUR 80 to EUR 150 per kg.

Source: SwissShrimp AG.

Model trout farms in Denmark

Denmark is without doubt the forerunner in environmentally friendly trout farming. Strict environmental regulations have forced trout farmers to introduce new technology to minimize the discharge from their farms. Recirculation was introduced by developing so-called model fish farms to increase production while lowering environmental impact. Instead of using huge amounts of water from the river, a limited amount of ground water from the upper layers is pumped into the farm and recirculated. The effect is significant; a more constant water temperature all year round together with a modern and more easily managed operation results in higher growth rates and higher efficiency with reduced production costs, depreciation of the investment included. The positive effect on the environment can be seen in Chapter 6.

Figure 8.5 A Danish model farm



Source: Kaare Michelsen, Danish Aquaculture.

Indoor low-cost RAS

The Danish model farms are typically outdoor farms and therefore to some extent at risk from changes in the weather, diseases and predators. Building indoor RAS usually increases costs and focus is often turned towards rearing of high value species that is not in the interest of farmers producing fish of lower value. This has opened a window for simpler technical solutions that are cheaper to build and offer lower running costs.

An example of such a RAS has been built in Denmark by the company FREA Solutions to produce rainbow trout, partly fry and fingerlings for on-growing and partly 300–400 g portion sized trout for processing. Technology is kept to a minimum and consists of low head propeller pumps for the main water flow, low pressure fans for degassing and roots blowers for moving bed biofilters. Pure oxygen is dissolved using a passive system based on gravity (see oxygen platform described in Chapter 2) and removal of particles based on sedimentation and fixed bed filtration. Besides a relatively low investment the energy consumption is documented to be below 2 kWh per kg fish produced.

Figure 8.6 The FREA Solutions fish farm produces 25 million rainbow trout per annum sold at sizes from 4 g to 400 g for on-growing or processing



*The new water used in the system, also called make-up water, is pumped from drains in the sandy ground below and reject water is released for seepage in the same area. The farm has no direct connection to rivers.
Source: FREA Solutions.*

Recirculation and re-stocking

Clean rivers, lakes, and natural wild stocks have become an important environmental goal in many countries. Conserving nature by restoring natural habitats and re-stocking endangered fish species or strains is one among many initiatives.

Sea trout is a popular sport fish that occupies many rivers in Denmark, where almost every river has its own strain. Genetic mapping carried out by scientists has made it possible to distinguish between different strains. When the sea trout matures, it migrates back from the sea to its home river to spawn. In the part of Denmark called Funen, rivers have been restored and the remaining wild strains have been saved by a re-stocking programme involving recirculation aquaculture. Mature fish are caught by electrical fishing and eggs are stripped and reared in a recirculation facility. Approximately one year later, the offspring are re-stocked in the same river from where their parents were caught.

Different strains have been saved and in due course the sea trout will hopefully be able to survive by itself in this habitat.

Most importantly, this programme has resulted in a significantly better chance of catching sea trout when anglers fish from the shores of Denmark. Fishing tourism has therefore become a good earning for local businesses such as hotels, camping sites, restaurants, etc. All in all, a win-win situation for both nature and local commercial interests.

Figure 8.7 Mature sea trout that have migrated up river for spawning are caught by electrical fishing and transported to a recirculation facility where the eggs are fertilized. One year later the juveniles are re-stocked in the same river where the parents were caught



Source: Linda Bollerup, FGU Fyns Laksefisk, Denmark.

Aquaponics

Growing plants and fish together was accomplished already thousand years ago in ancient China. The plants grow using the nutrients excreted from the fish, and both fish and plants can be harvested for consumption. In modern aquaculture the combination of growing fish in a recirculation system and growing greenhouse plants in hydroponics using nutrient water without soil is named “aquaponics”. The technology has been successfully commercialised in countries like the United States of America but is not yet economically viable in colder regions, such as northern Europe.

Figure 8.8 Aquaponics research at the Institute of Global Food and Farming near Copenhagen, Denmark

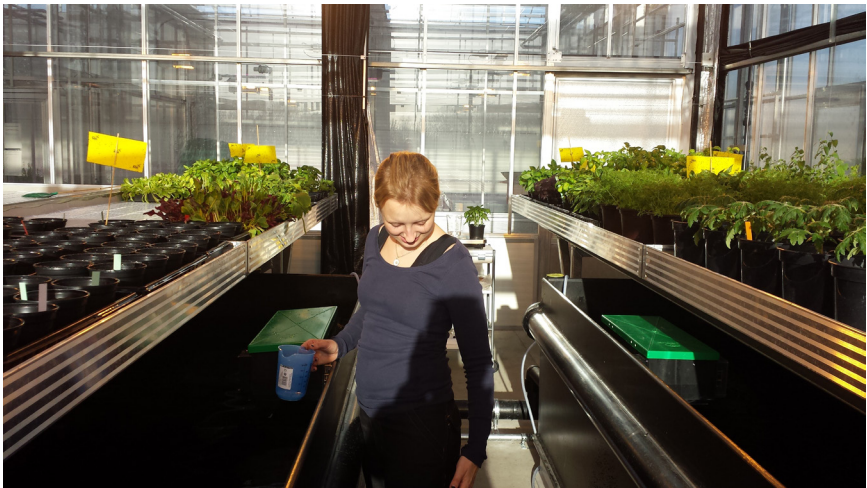

The system is built in an existing greenhouse facility and includes fish rearing tanks and salad tables together with a recirculating water system with two independent water loops. One of the loops run through a water filtering system and can be routed to plant tables or back to fish tanks. The other loop supplies water directly to plant tables for growing lettuce or herbs such as sage, basil and thyme.
Source: Paul Rye Kledal, Institute for Global Food and Farming.

Land based salmon farming

The size of fish farms is constantly growing as world production in aquaculture rises. Today, an average sea cage farm in the sea of Norway produces around 5 000 tonnes of salmon per site. Land based systems of this size are catching up and new recirculation projects of these volumes are emerging.

Combining land-based farms with cage farming is a very efficient way of production and today probably the most competitive set-up for salmon species. Small fish are produced on land in efficient and controlled systems before they are released into large net pens at sea for grow-out. In some areas cage farming is not popular, and land-based farms in the form of recirculation plants are seen as a way of producing farmed fish in the future. Their footprint is low and so is the water consumption. Although production costs are still higher than in cages, the systems have high food safety, complete control of all parameters (oxygen, ammonium, nitrite, carbon dioxide, suspended solid levels, temperature, pH, salinity etc.), and the output is constant and foreseeable. Furthermore, these farms can be built close to large cities for local production and supply, saving costs of transportation and reducing CO₂ emissions.

Figure 8.9 The company Danish Salmon was one of the very first pioneers in commercial land-based salmon farming



This 2 000 tonnes salmon farm in Hirtshals, Denmark was built in 2013. The system is based on recirculation technology and is covered by a building to control temperature and for high biosecurity. Salmon are grown from eggs to around 4–5 kg size in 2 years in large tanks of almost 1 000 m³ each. The white bigbags in the foreground are packed with biomedica ready to be filled into the biofilter chambers. Source: Axel Sjøgaard/AKVA group.

Future of recirculation

The number of RAS for juvenile production of many different fish species will continue to grow as the need for healthy and strong offspring supplied throughout the year is the basic of improving efficiency in fish farming. The supply from commercial fishing has reached its limit and now more than half the human consumption of fish and seafood comes from aquaculture. The supply gap in the fish and seafood market can only be filled by products produced in aquaculture.

In the salmon sector we will see a significant growth in large smolt facilities moving the first part of the cage farming period on land to grow fish faster in a more secure environment. Hereto huge land-based salmon farms for growing salmon to market size will emerge around the world.

Producing fish in RAS right next to consumers in large cities will provide fresh fish at high quality, save CO₂ emissions by eliminating long freight routes and improve self-sufficiency in the countries concerned. Projects of this kind are reaching for volumes of 5 000 tonnes per year and beyond, and not all of them are salmon. Yellowtail kingfish is next in line and other species may be expected to join this trend, shrimp included.

The projects of the future will also benefit from increased automatization like washing of biofilters and constant control of pumps and other machinery to save power. The use of digitalization, computer vision (deriving meaningful information from images and video) and machine learning will increase, and artificial intelligence will be a part of improving performance, such as monitoring of swimming behaviour for early warning or predicting of appetite ahead of time.

Figure 8.10 Building huge RAS right next to larger cities around the world is a growing trend that will secure fresh fish for consumers, and improve self-sufficiency in the countries concerned



Source: Nordic Aqua Ningbo.

References

- Aquaetreat**, 2007. *Manual on Effluent Treatment in Aquaculture: Science and Practise* (Report). Outcome of the EU supported Aquaetreat.org project
- Avault J. W. Jr.**, 1996. *Fundamentals of Aquaculture, A Step-by-Step Guide to Commercial Aquaculture*, Baton Rouge, USA, AVA Publishing Company Inc., 1996, ISBN 0-9649549-0-7
- Barnabé, G., eds.**, 1990. *Aquaculture*, Volume 1 & 2, Chichester, England, Ellis Horwood Limited, ISBN 0-13-044108-2
- Brock, T. D., Smith, D. W. & Madigan M., T.**, 1984. *Biology of Microorganisms*, USA, Prentice-Hall International, ISBN 0-13-078338-2
- Brown, L.**, 1993. *Aquaculture for Veterinarians: Fish Husbandry and Medicine*, Oxford, UK, Pergamon Press Ltd., ISBN 008-040835
- FAO**. 2020. *The State of World Fisheries and Aquaculture 2020. Sustainability in action*. Rome. FAO. <https://doi.org/10.4060/ca9229en>
- Jokumsen, A. & Svendsen, L. M.**, 2010. *Farming of Freshwater Rainbow Trout in Denmark*, DTU Aqua, National Institute of Aquatic Resources. DTU Report no. 219-2010. ISBN 978-87-7481-114-5
- Lekang, O.**, 2020. *Aquaculture Engineering*, Norwegian University of Life Sciences, Drobakveien, Norway. Third edition, John Wiley & Sons Ltd, 2020, ISBN 9781119489016
- Remmerswaal, R.A.M.**, 1997. *Recirculating Aquaculture Systems*, INFOFISH Technical Handbook 8, ISBN 983-9816-10-1
- Timmons, M.B., & Ebeling, J.M.**, 2002. *Recirculation Aquaculture*, NRAC Publication No. 01-007, USA, Cayuga Aqua Ventures, ISBN 978-0-9712646-2-5
- Wheaton, F. W.**, 1993. *Aquacultural Engineering*, Malabar, Florida, USA, Krieger Publishing Company, 1993, ISBN 0-89464-786-5

Appendix

Checklist to be used when implementing a recirculation system		
1.0	Project information	
1.01	Describe aim, purpose, goal of project	
1.02	Species to be farmed	
1.03	Production per year, in tonnes, in numbers	
1.04	Size of fish in / out – production plan	
1.05	Number of batches per year	
1.06	Estimate of Feed Conversion Rate (FCR)	
1.07	Existing drawings or other information available	
1.08	Has discharge permission been granted? Restrictions, consent levels, etc.	
1.09	Available farm manager or fish specialist	
1.10	Other vital information, special problems, etc.	
2.0	Site information	
2.01	Is it saltwater or freshwater? Salt content of seawater	
2.02	Available water source. Seawater, river, well, ground water, borehole	
2.03	How much water is available? Litres / second	
2.04	Water temperature. Summer / winter Day / night fluctuations	

2.05	Water analysis Results pH	
2.06	Weather conditions, max / min air temperature Hard winters, extreme summer heat, etc.	
2.07	Building ground conditions	
2.08	Ground temperature, max / min	
2.09	Ground area available Shape of building area	
2.10	Available space for wastewater treatment Settlement ponds, seepage area, etc.	
2.11	Ground level zero reference	
2.12	Local power supply, specify	
3.0	Content of facility	
3.01	Hatchery	
3.02	Nursery / First feed	
3.03	Pre grow-out / Fry	
3.04	Grow-out	
3.05	Broodstock	
3.06	Live feed production	
3.07	Purge unit	
3.08	Quarantine unit – in Acclimatization unit – out	
3.09	Water intake treatment	
3.10	Wastewater treatment	
3.11	Grading / Harvesting / Live Delivery	

Appendix

3.12	Processing / Packing Cold store / Ice machine	
3.13	Laboratory / Workshop Office / Canteen	
3.14	Emergency generator	
3.15	Oxygen generator / Emergency oxygen tank	
3.16	Water heating / Chilling system	
3.17	Building requirements, Insulation	
3.18	Architecture, Surroundings	

Key features

- Assists farmers to convert to recirculation aquaculture
- Introduces the technology and the methods of management
- Advises on good practice shifting to recirculation aquaculture
- Specifies running a recirculation system, staff education and training
- Provides case stories from different recirculation projects

The author, Jacob Bregnballe, from the AKVA group has worked all over the world with recirculation aquaculture in research and practice for more than 40 years. He has run his own fish farm in Denmark for 25 years, and has been involved in many technological innovations for improving recirculation systems for a wide range of different aquaculture species.

This guide is jointly published by the Food and Agriculture Organization of the United Nations (FAO) and Eurofish International Organisation.

Eurofish International Organisation
H.C. Andersens Boulevard 44-46
DK-1553 Copenhagen V
Denmark

FAO Regional Office for Europe
and Central Asia
20 Kalman Imre utca
H-1054 Budapest
Hungary

Tel.: (+45) 333 777 55
info@eurofish.dk
www.eurofish.dk

Tel.: (+36) 1 4612000
FAO-RO-Europe@fao.org
www.fao.org/europe

ISBN 978-92-5-136981-4



9 789251 369814

CC2390EN/1/10.22